

VIETMOBILE.VN

SH601

SH300

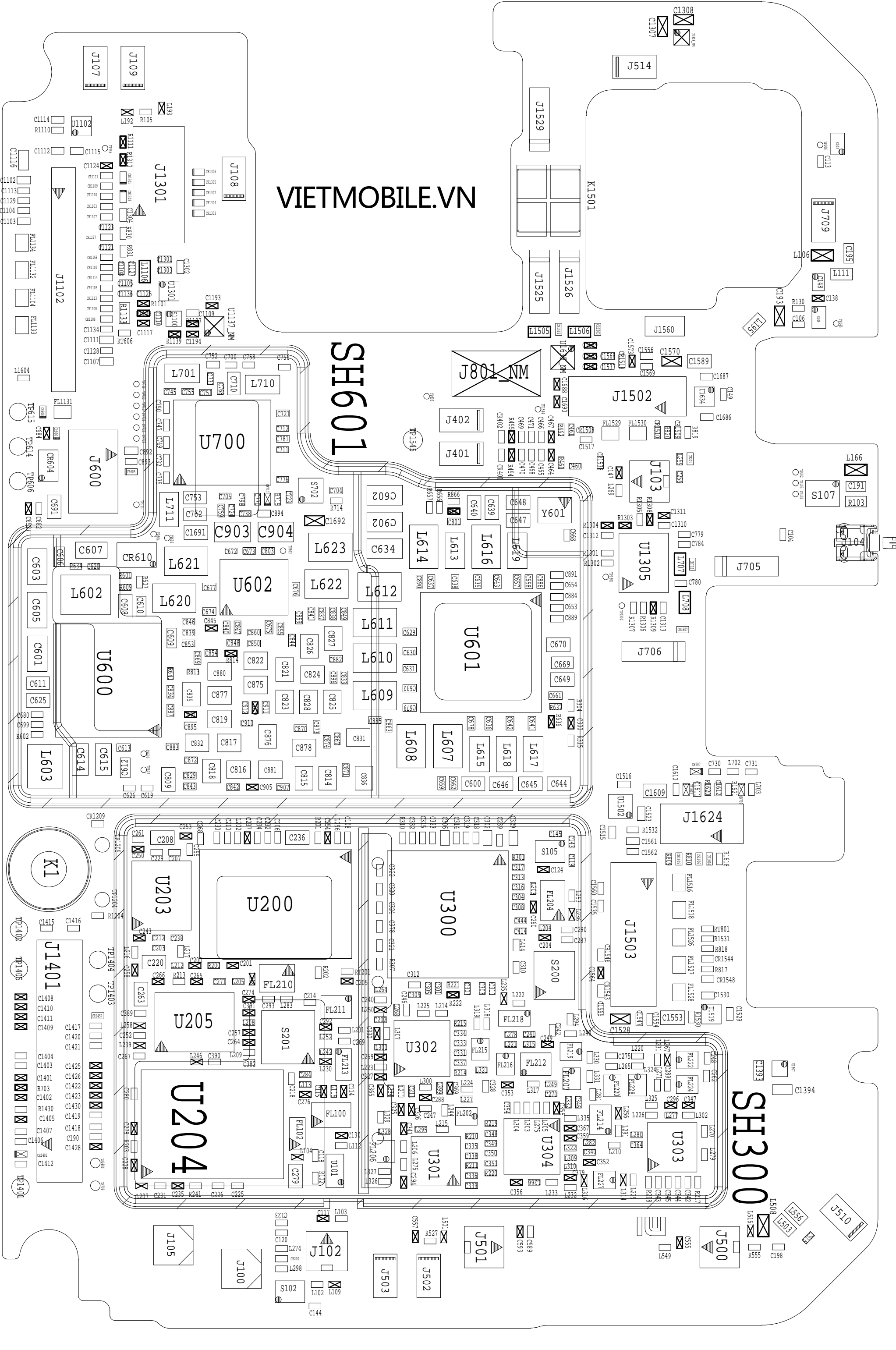



# DRX\_ANT

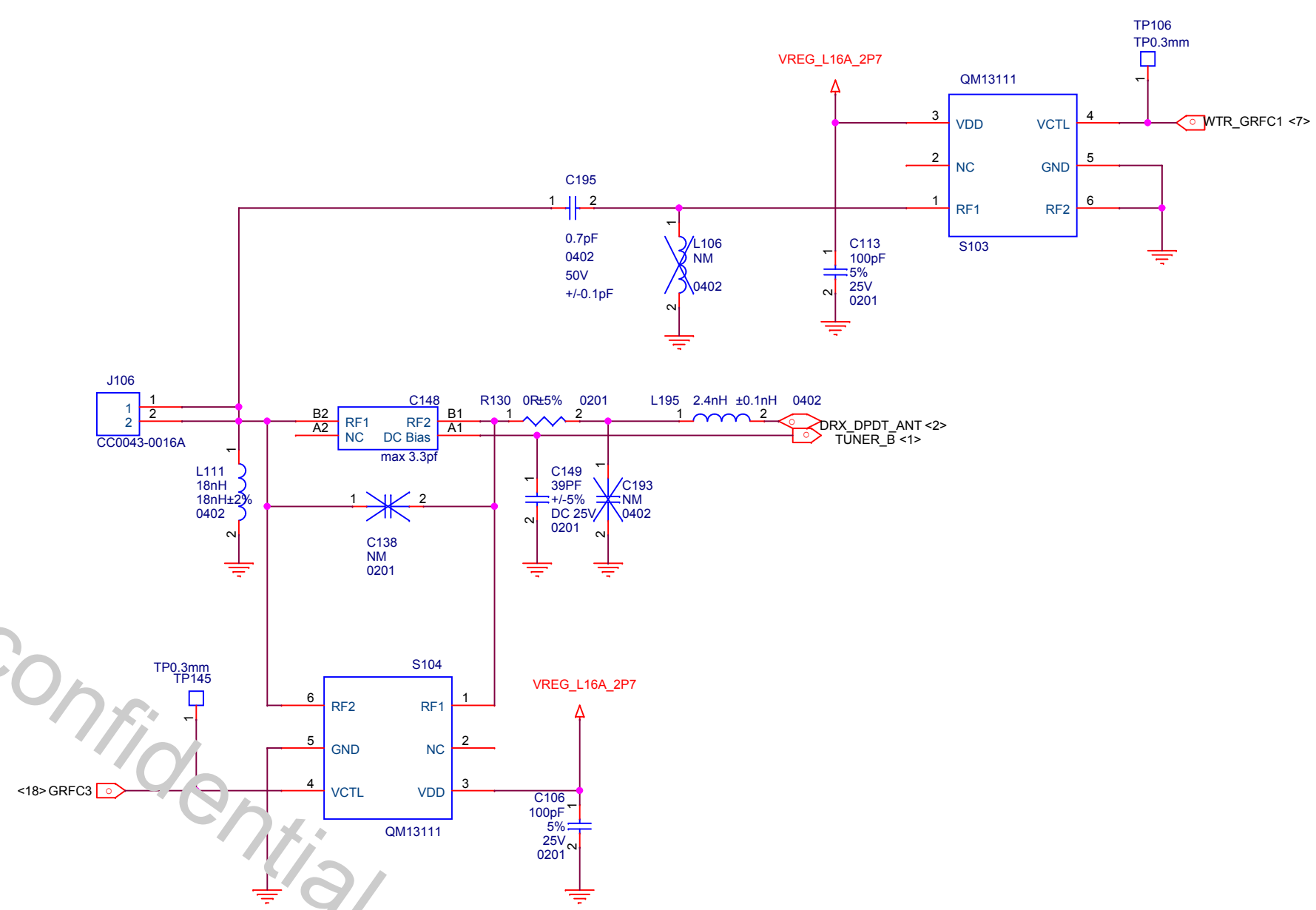
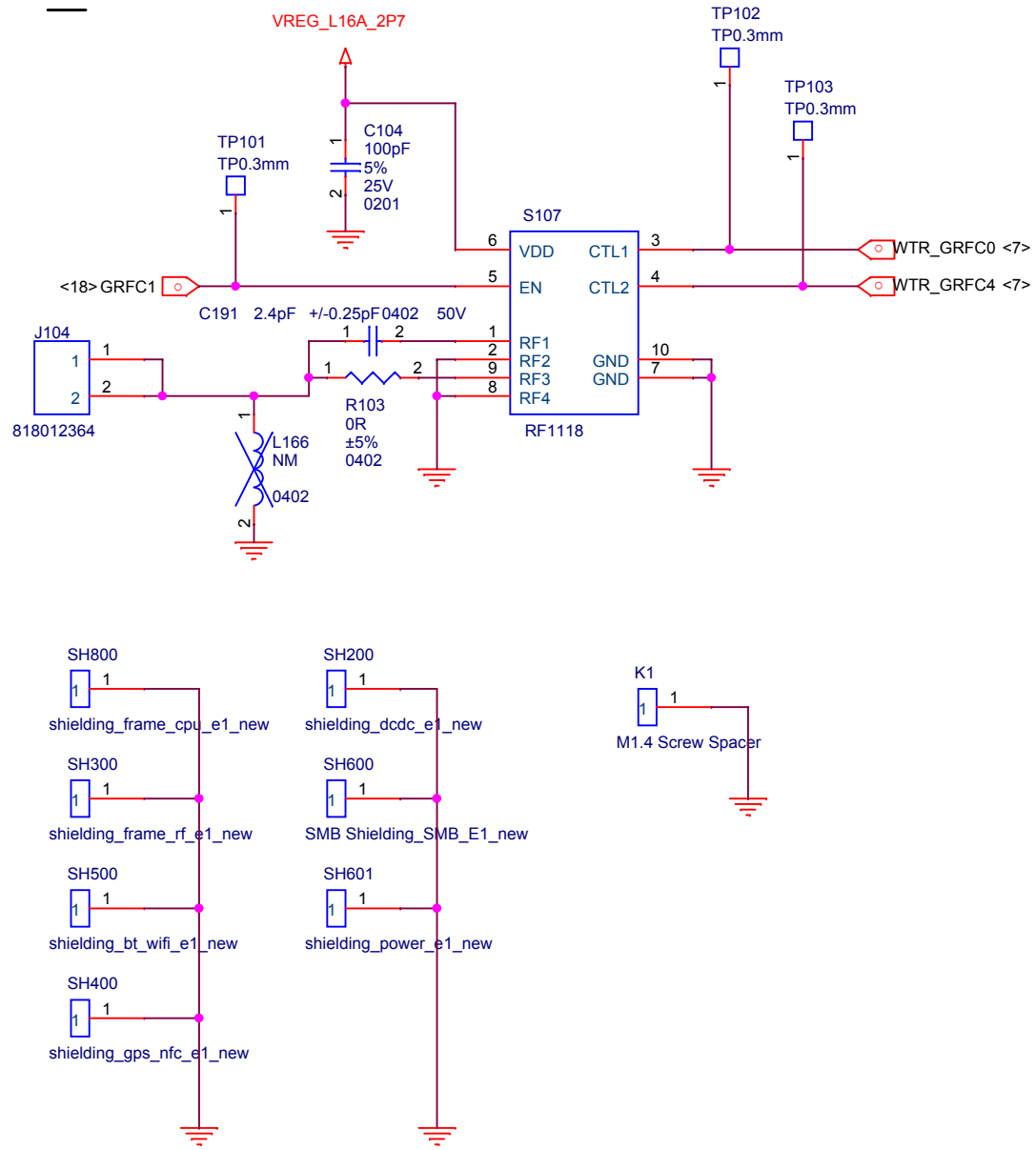

# TUNER\_CTR

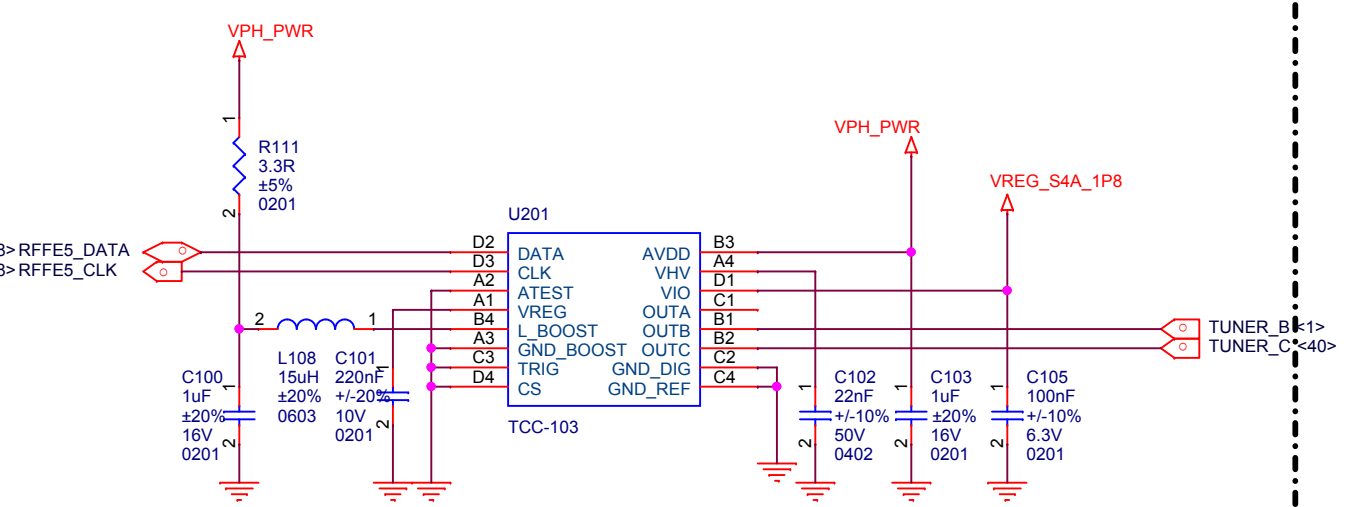

# 4X4\_MIMO\_ANT3

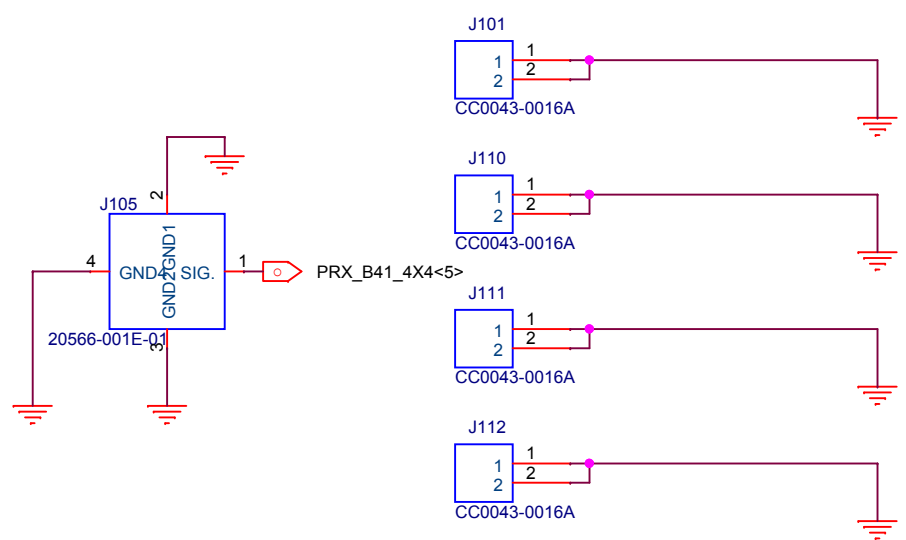

# 4X4\_MIMO\_ANT4

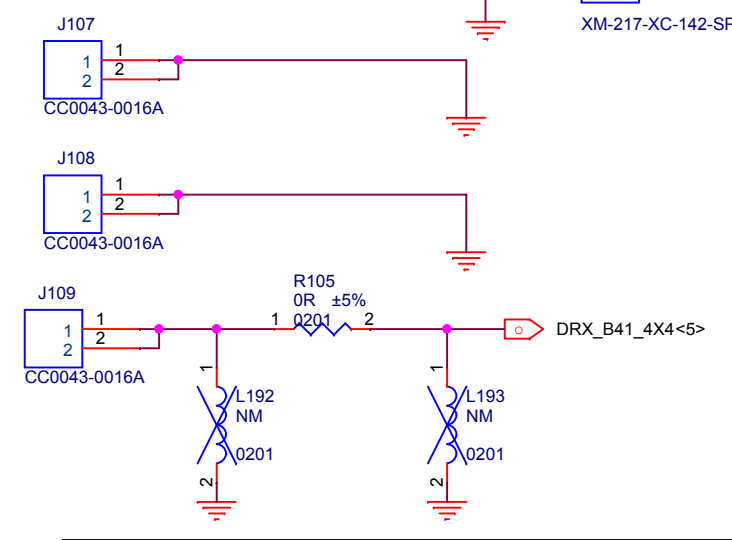

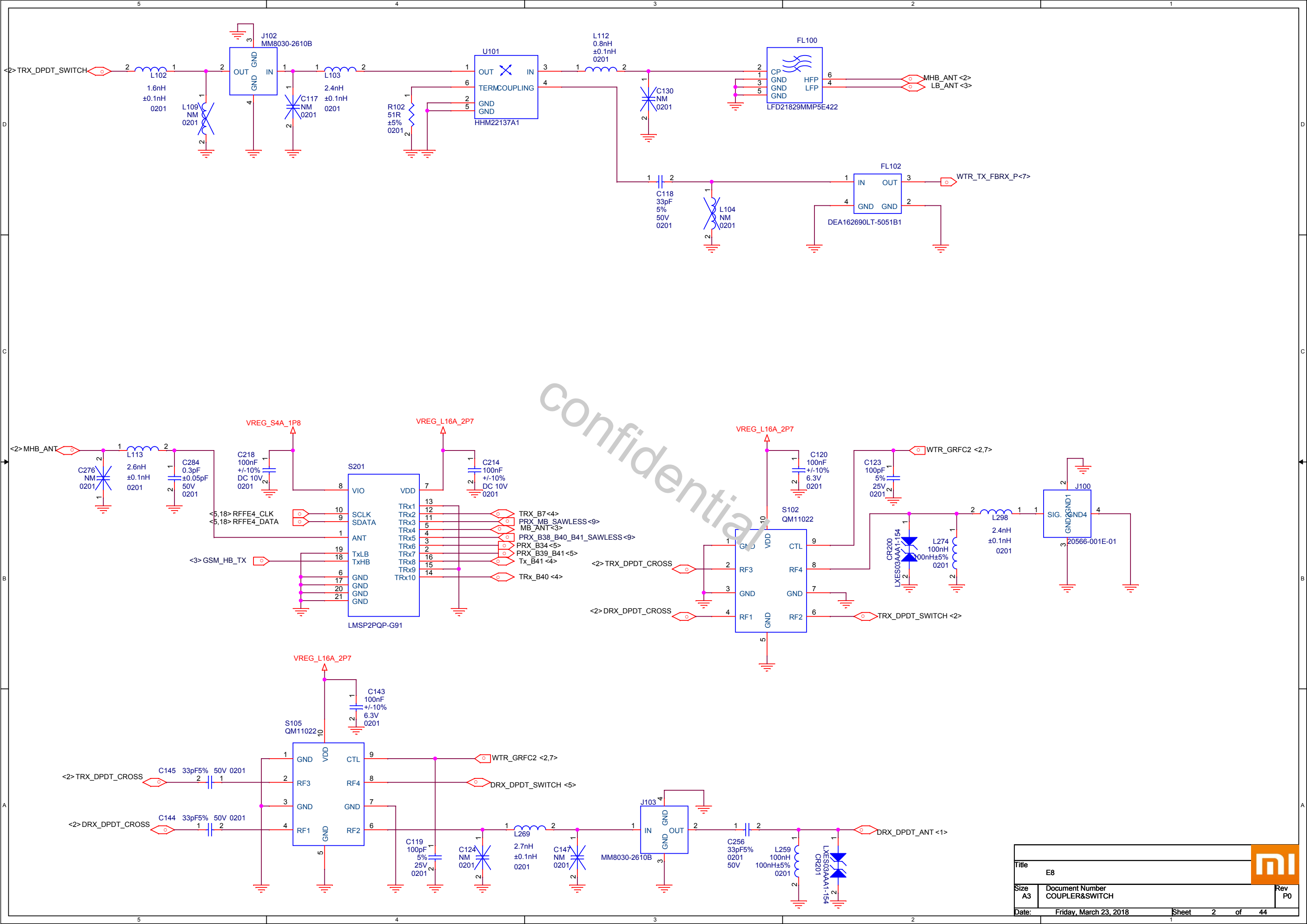

Confidential

|       |                        |                |   |
|-------|------------------------|----------------|---|
| Title |                        | E8             |  |
| Size  | Document Number        | COUPLER&SWITCH |   |
| Date: | Friday, March 23, 2018 | Sheet 2 of 44  | Rev P0  |

# 2GPA

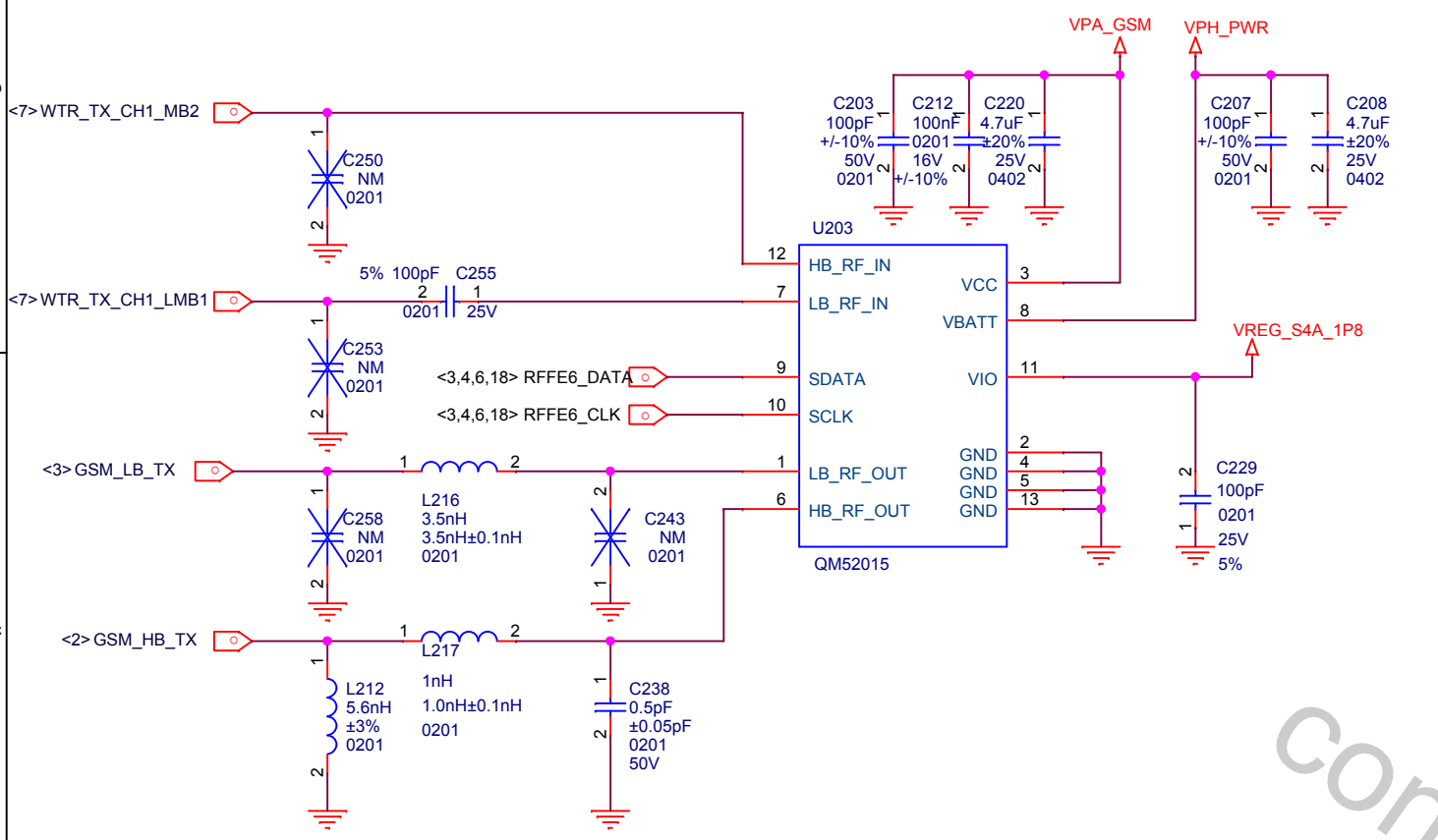

# LBPA

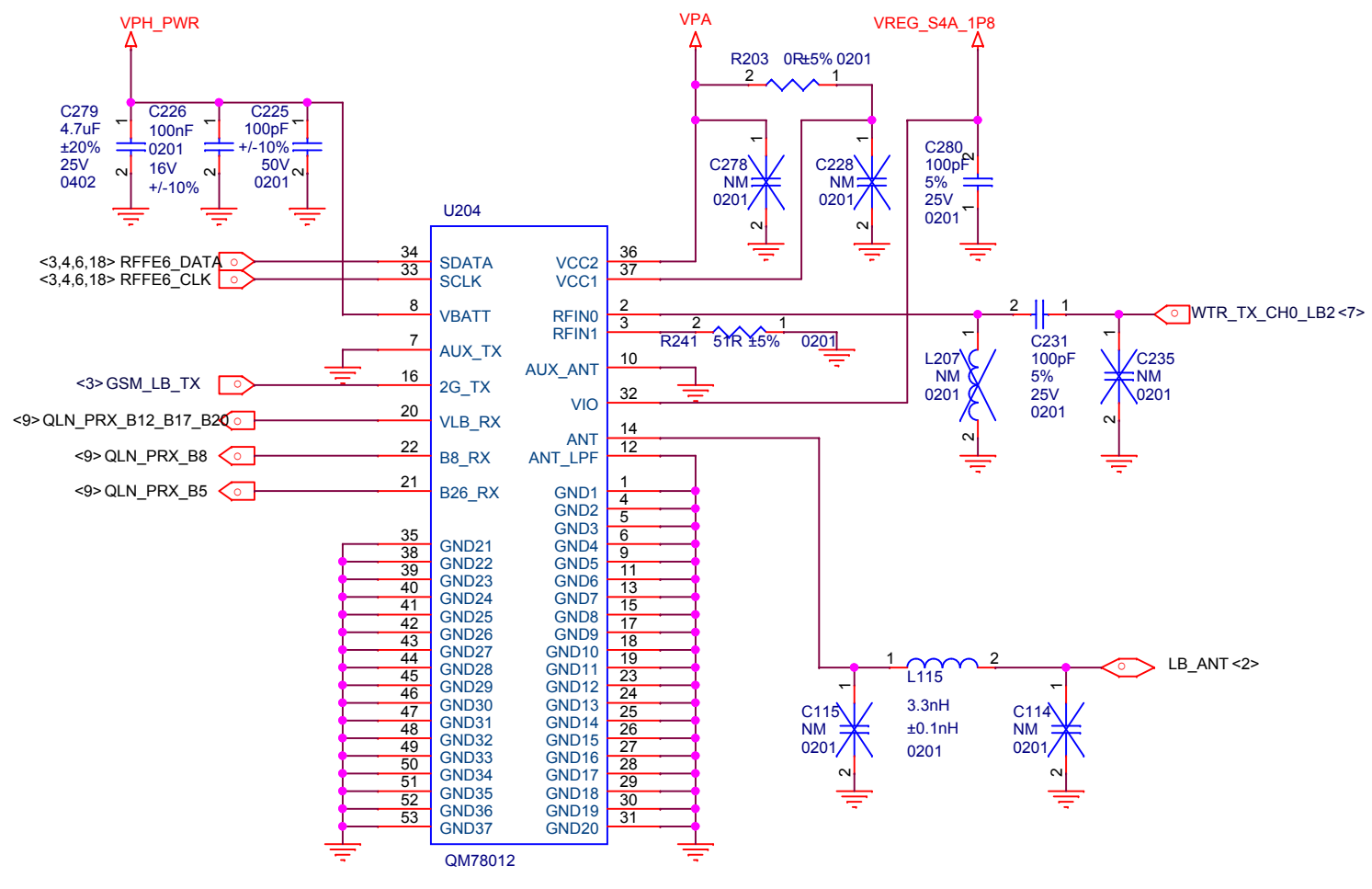

Confidential

# MBPA

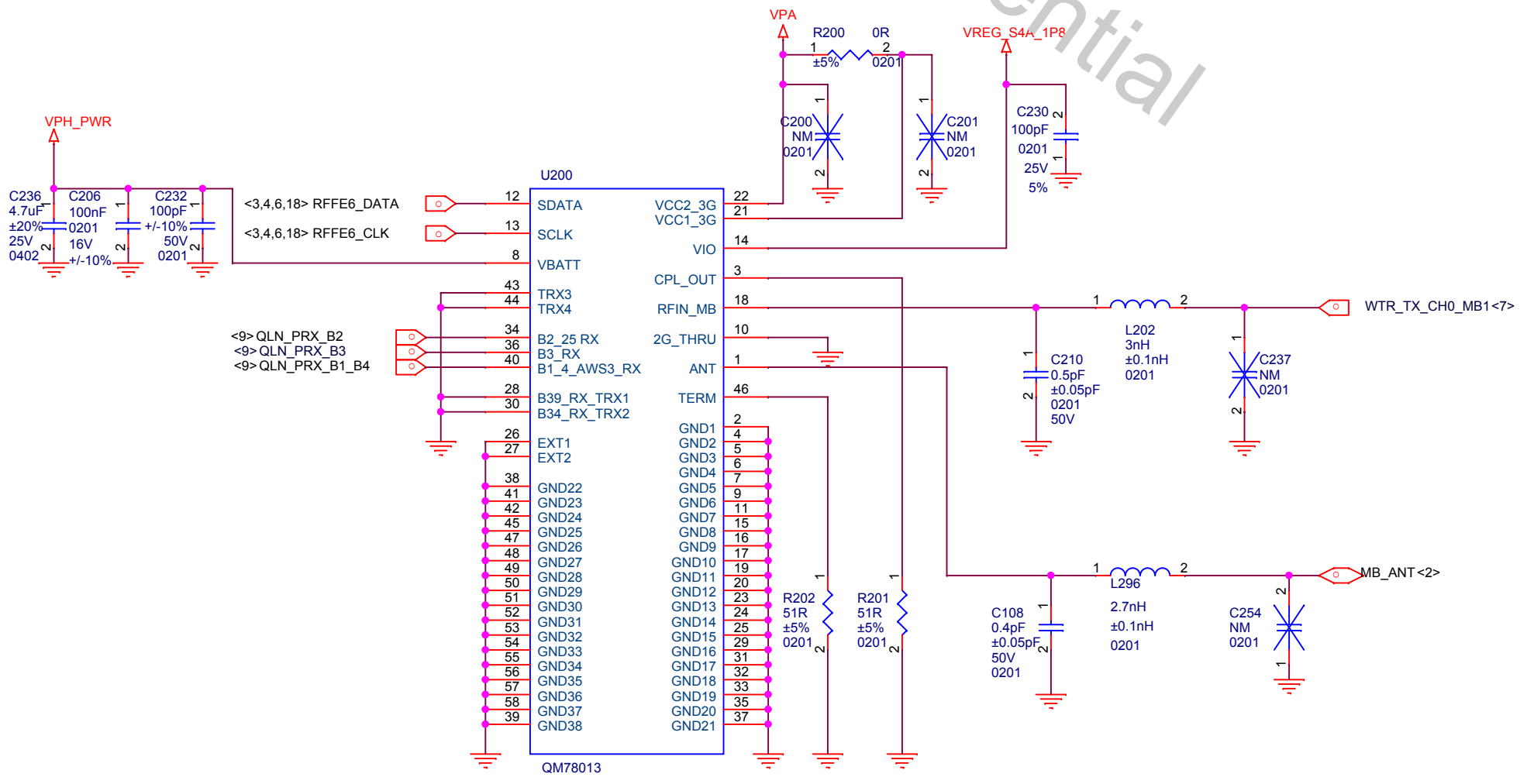

|       |                        |             |         |
|-------|------------------------|-------------|---------|
| Title |                        | E8          |         |
| Size  | Document Number        | 2G&LB&MB PA |         |
| Date: | Friday, March 23, 2018 | Sheet       | 3 of 44 |
| Rev   | P0                     |             |         |

# HBPA

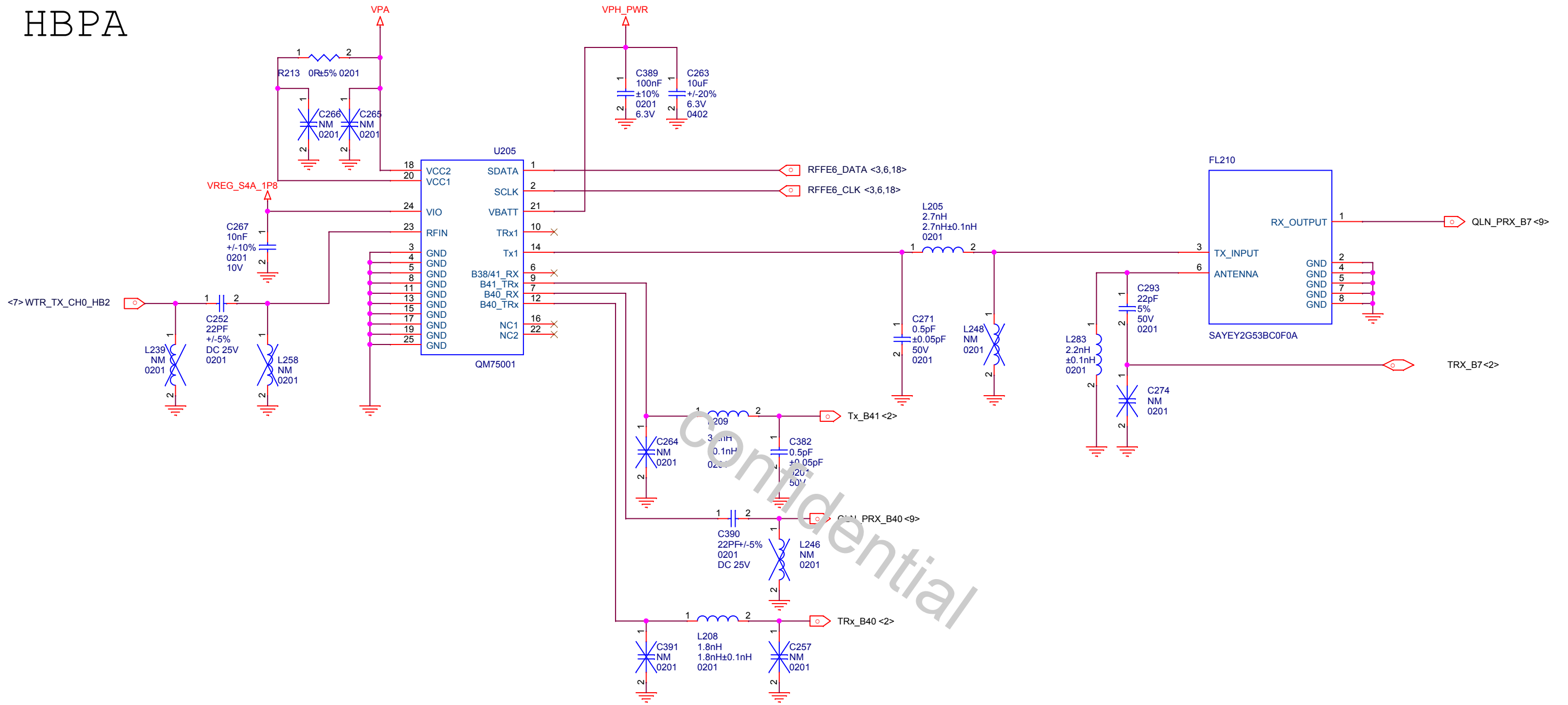

# PA THERM

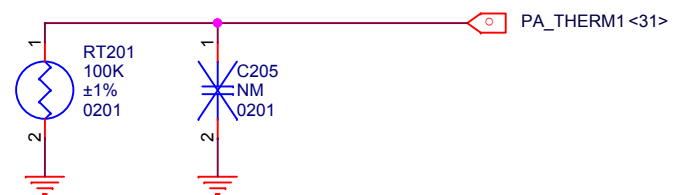

|       |                        |                 |   |       |
|-------|------------------------|-----------------|---|-------|
| Title |                        | E1              |   |       |
| Size  | Document Number        | HBPA & PA THERM |   |       |
| A3    |                        |                 |   | P0    |
| Date: | Friday, March 23, 2018 | Sheet           | 4 | of 44 |

# PRX B34 B39 B41

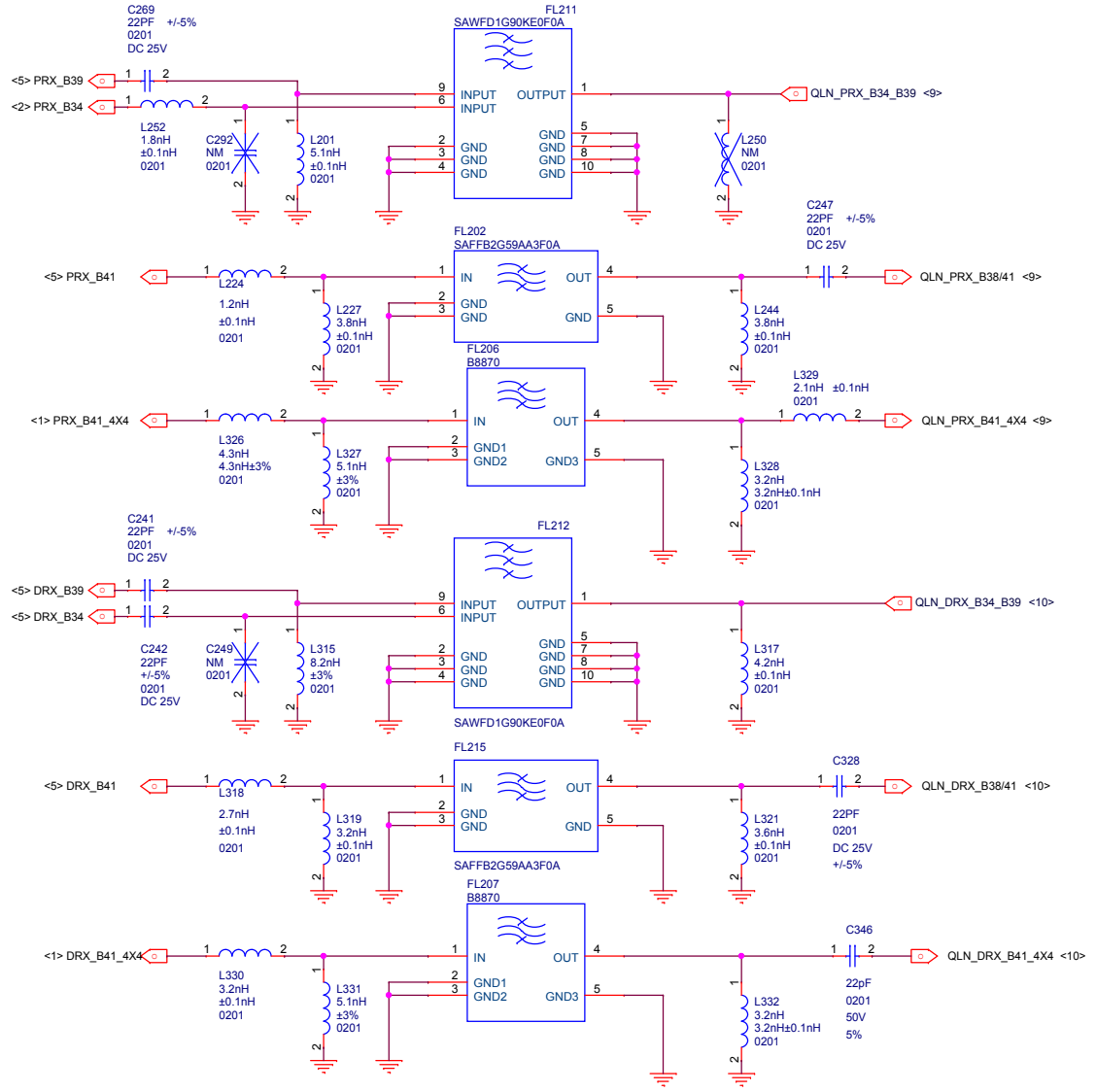

# DIPLEXER B39 B41

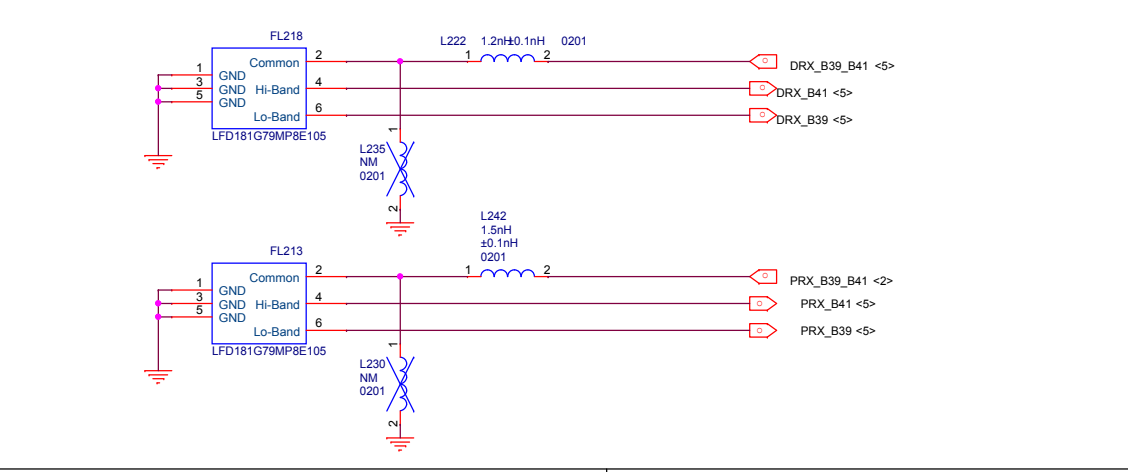

# DRX

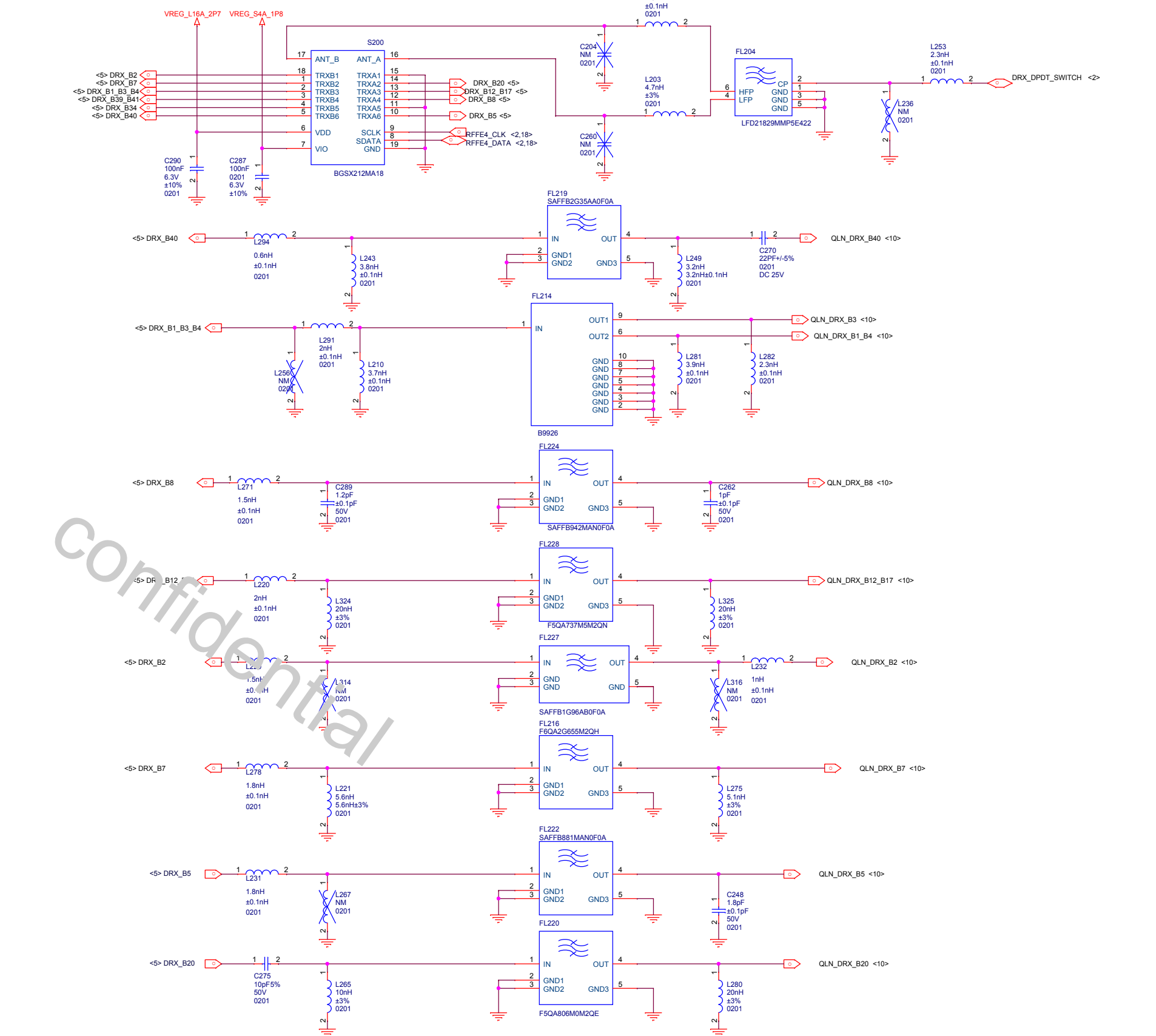

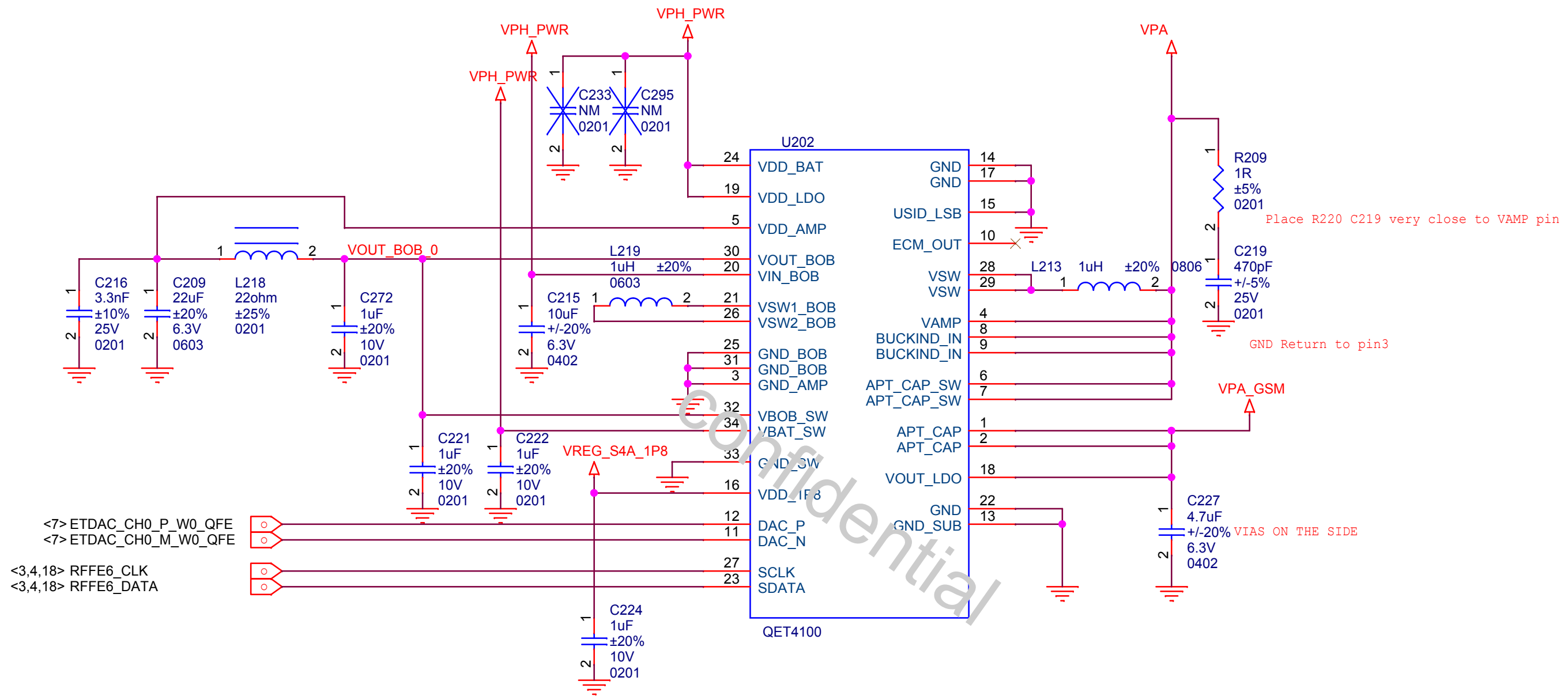

<7> ETDAC\_CH0\_P\_W0\_QFE  
 <7> ETDAC\_CH0\_M\_W0\_QFE  
 <3,4,18> RFFE6\_CLK  
 <3,4,18> RFFE6\_DATA



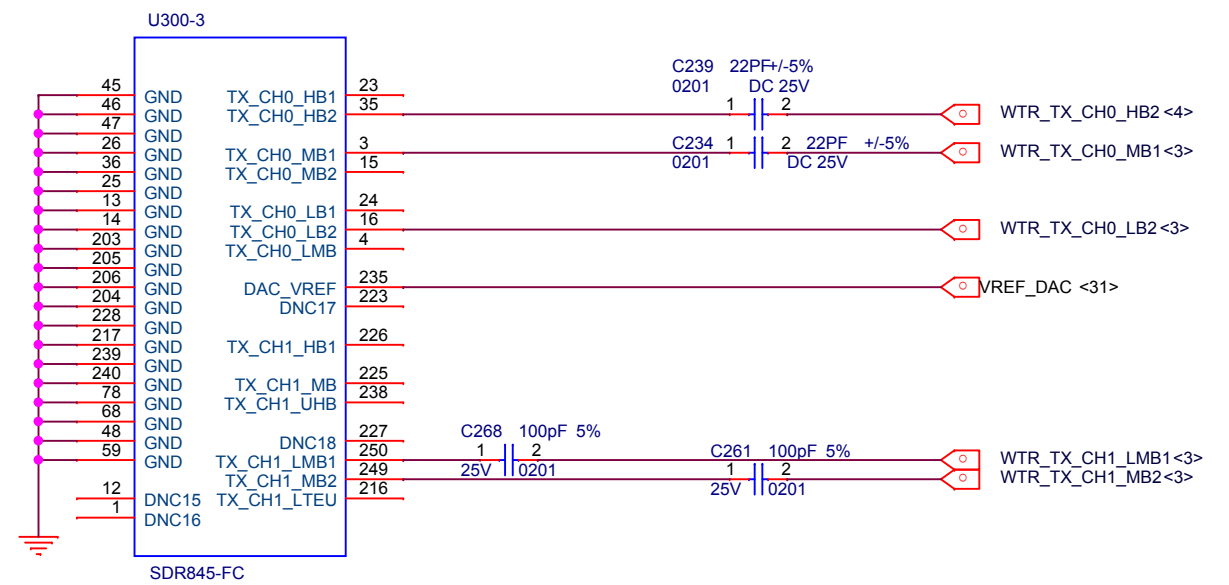
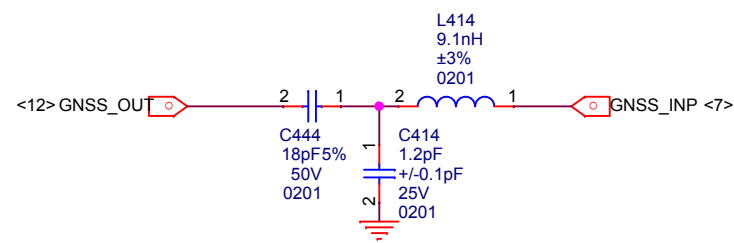
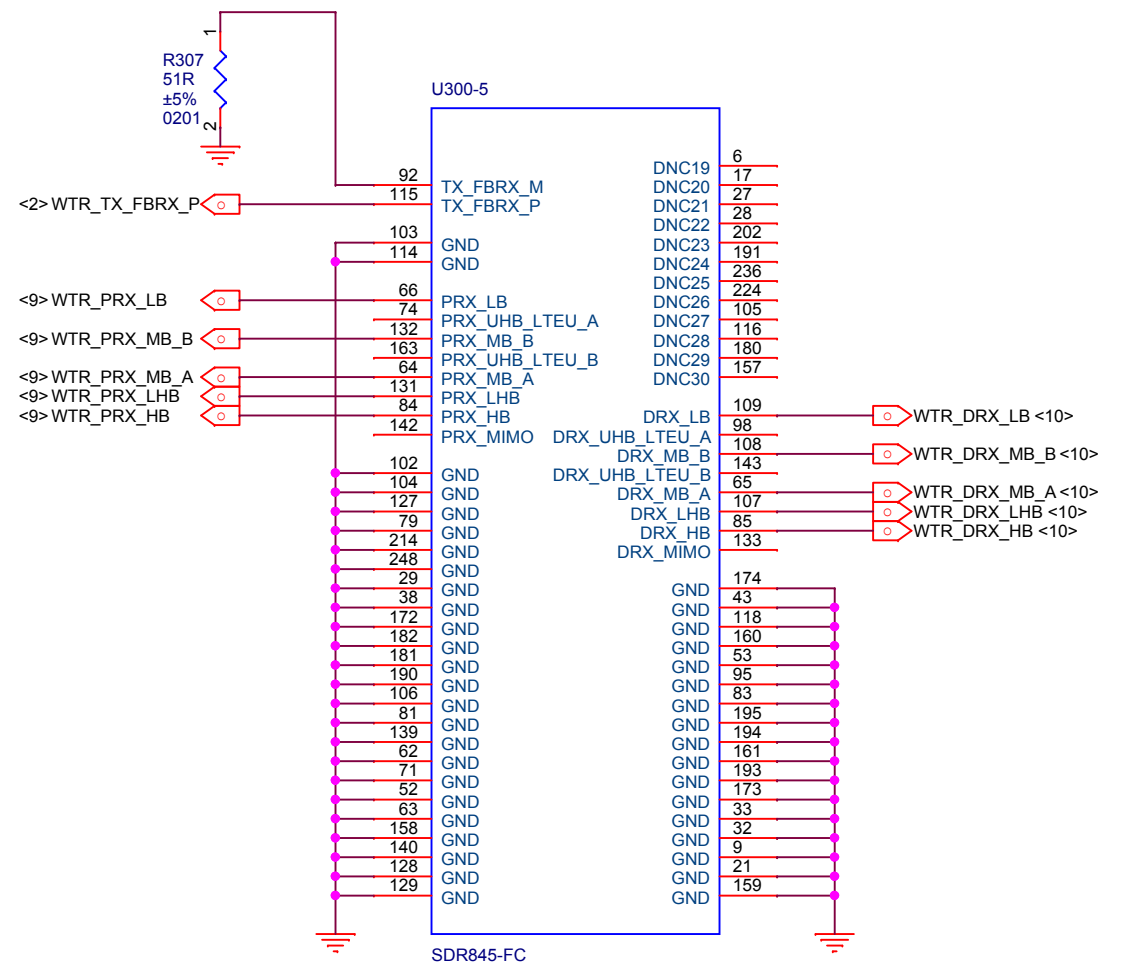
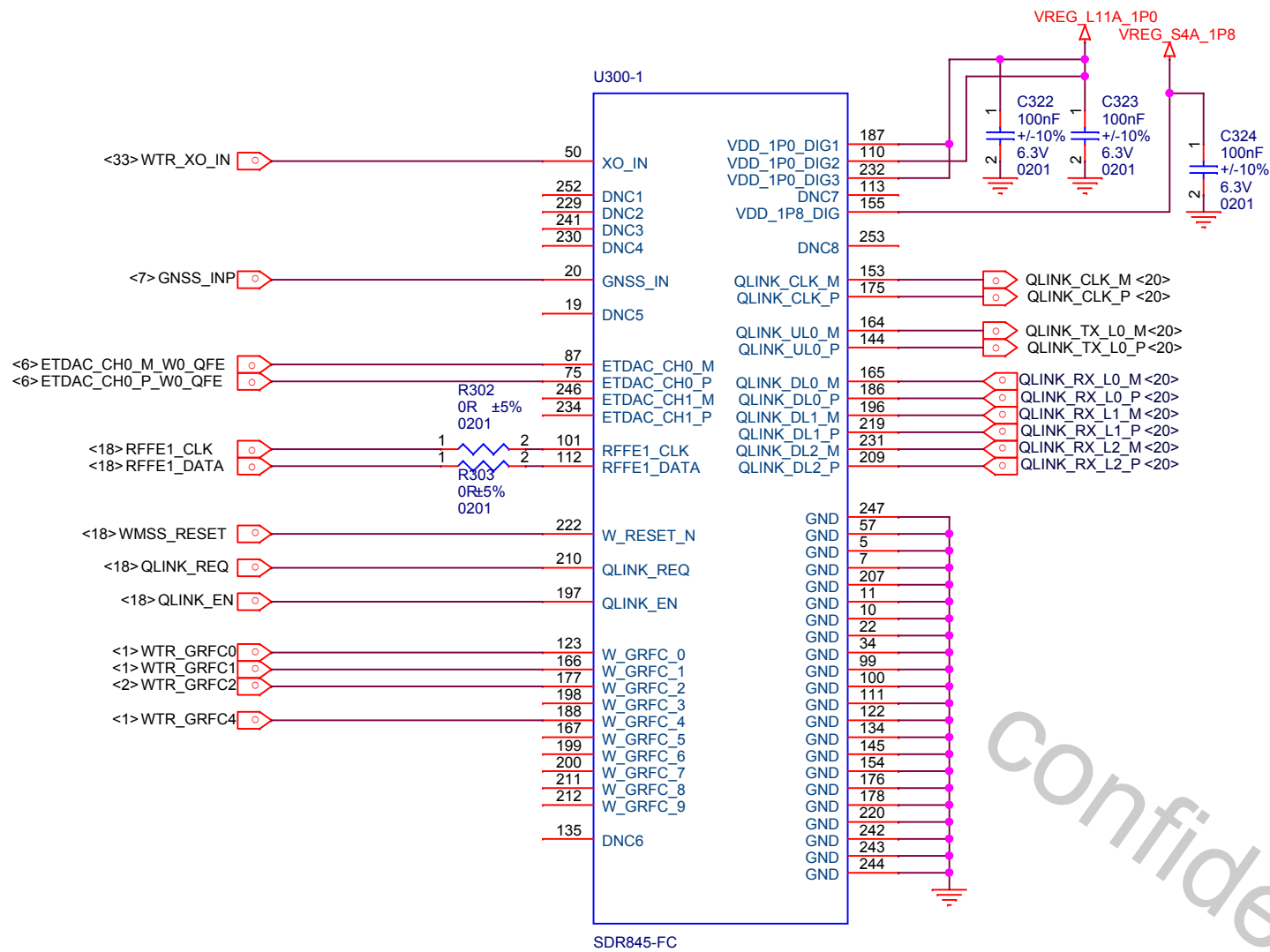

confidential

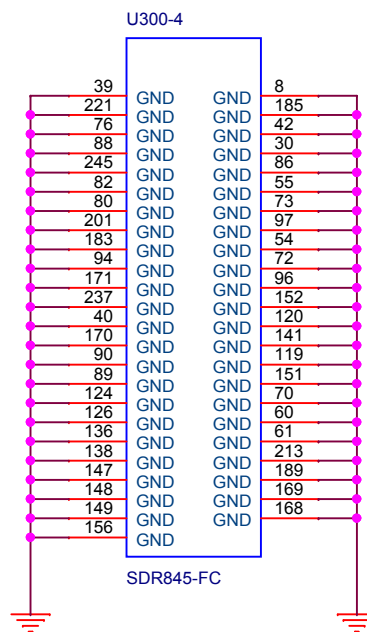
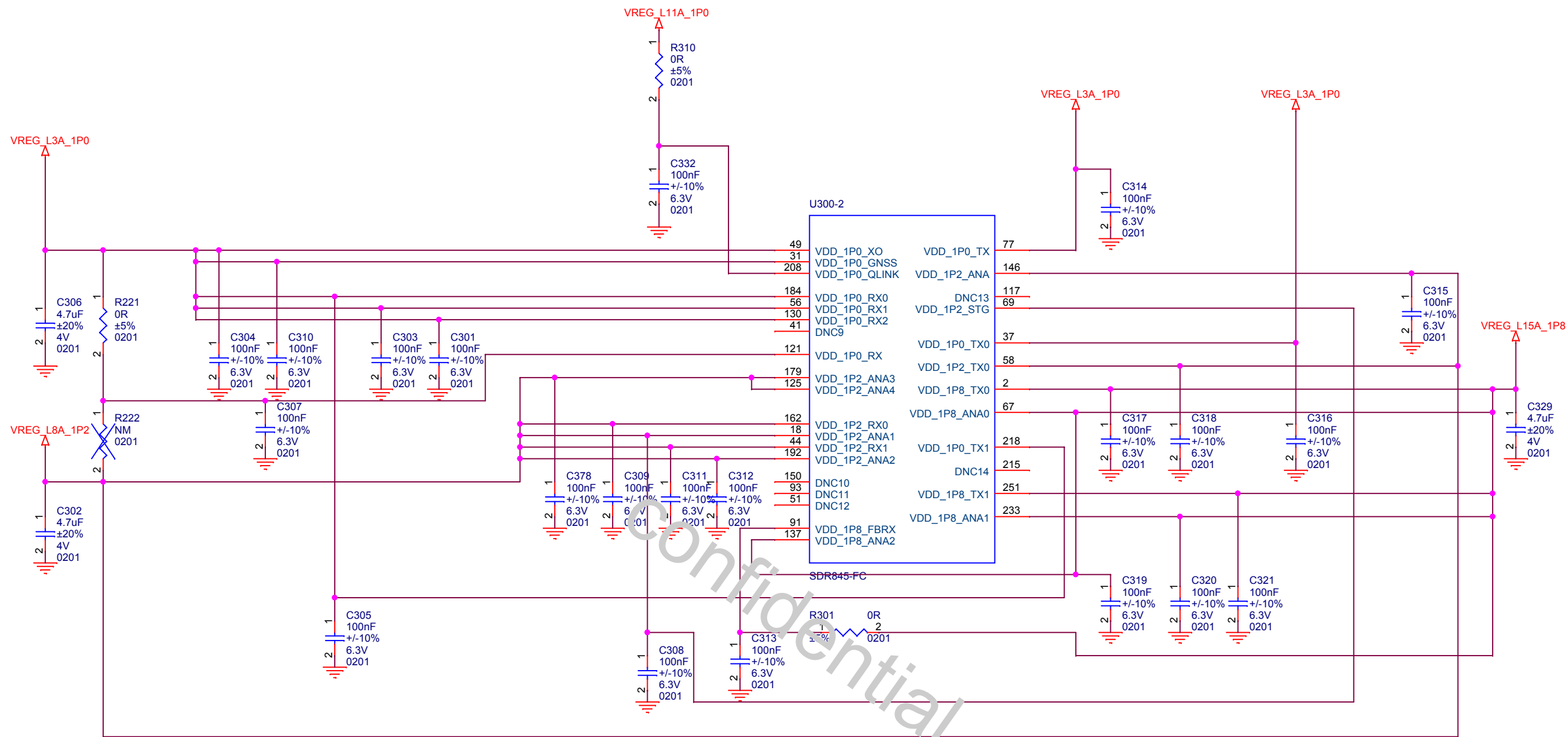

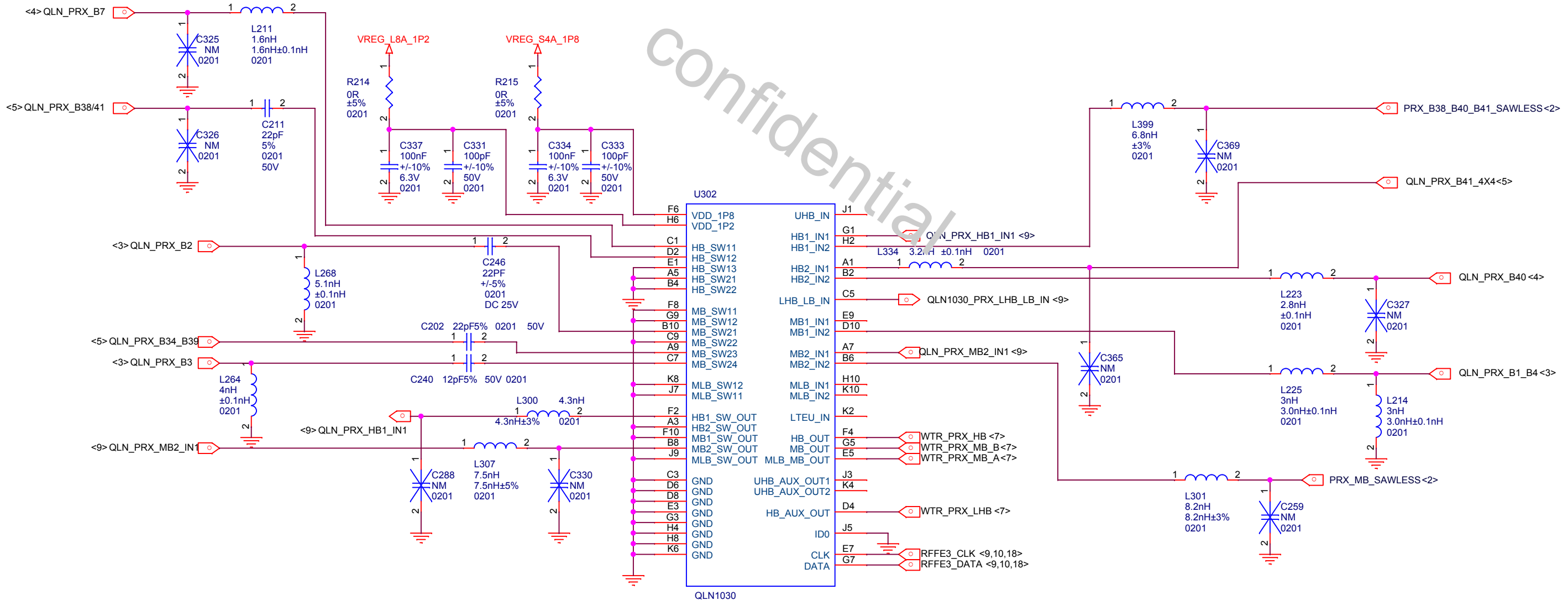
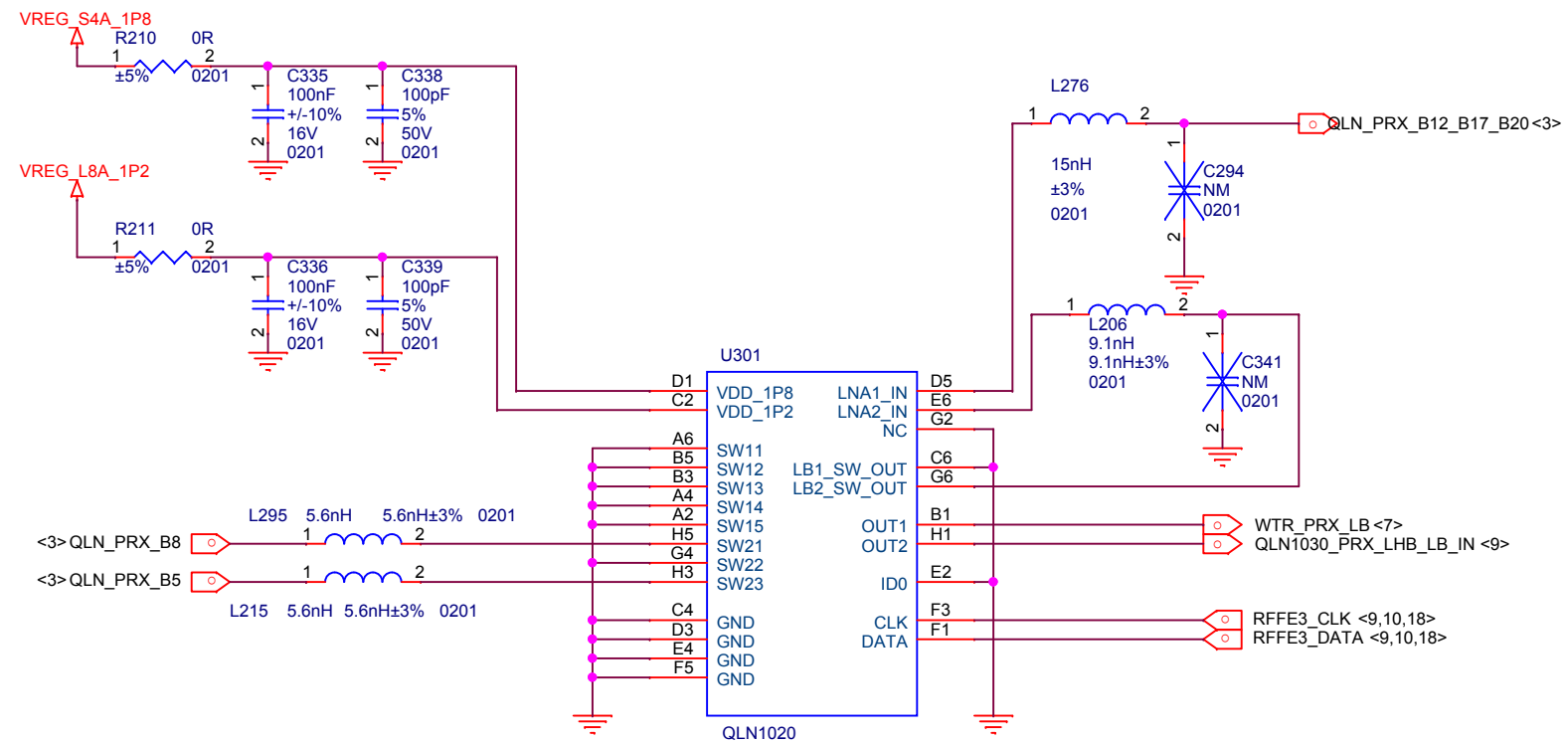

|       |                        |       |         |
|-------|------------------------|-------|---------|
| Title |                        | E8    |         |
| Size  | Document Number        | Rev   |         |
| A3    | QLN PRX                | P0    |         |
| Date: | Friday, March 23, 2018 | Sheet | 9 of 44 |

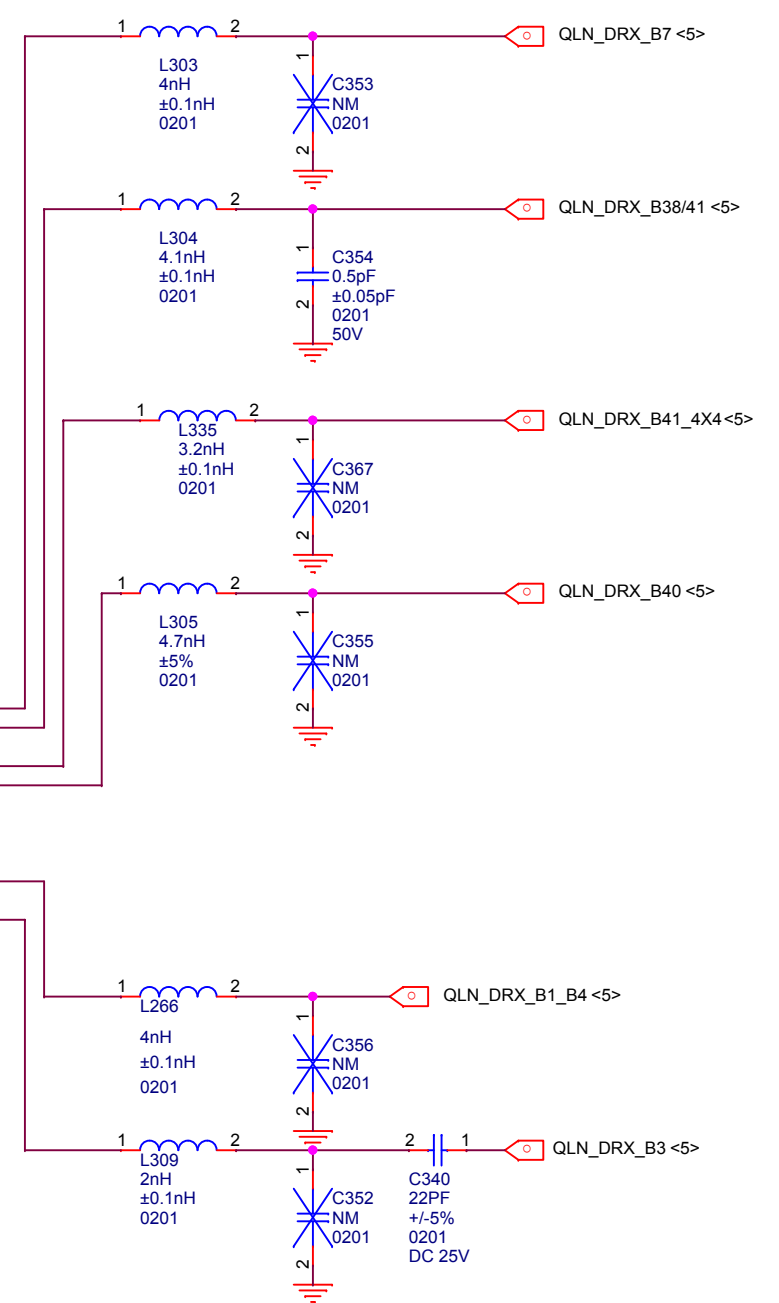
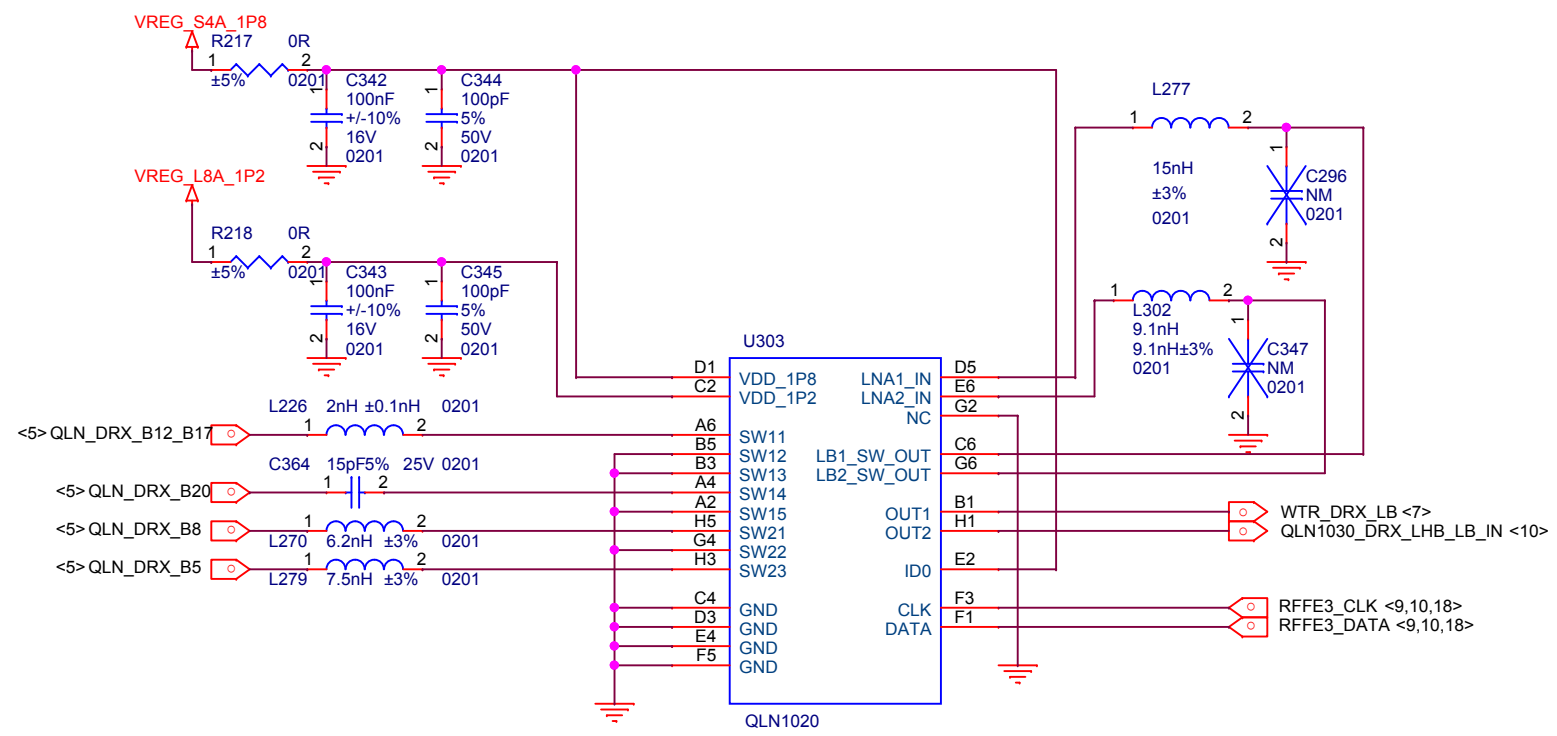

Confidential

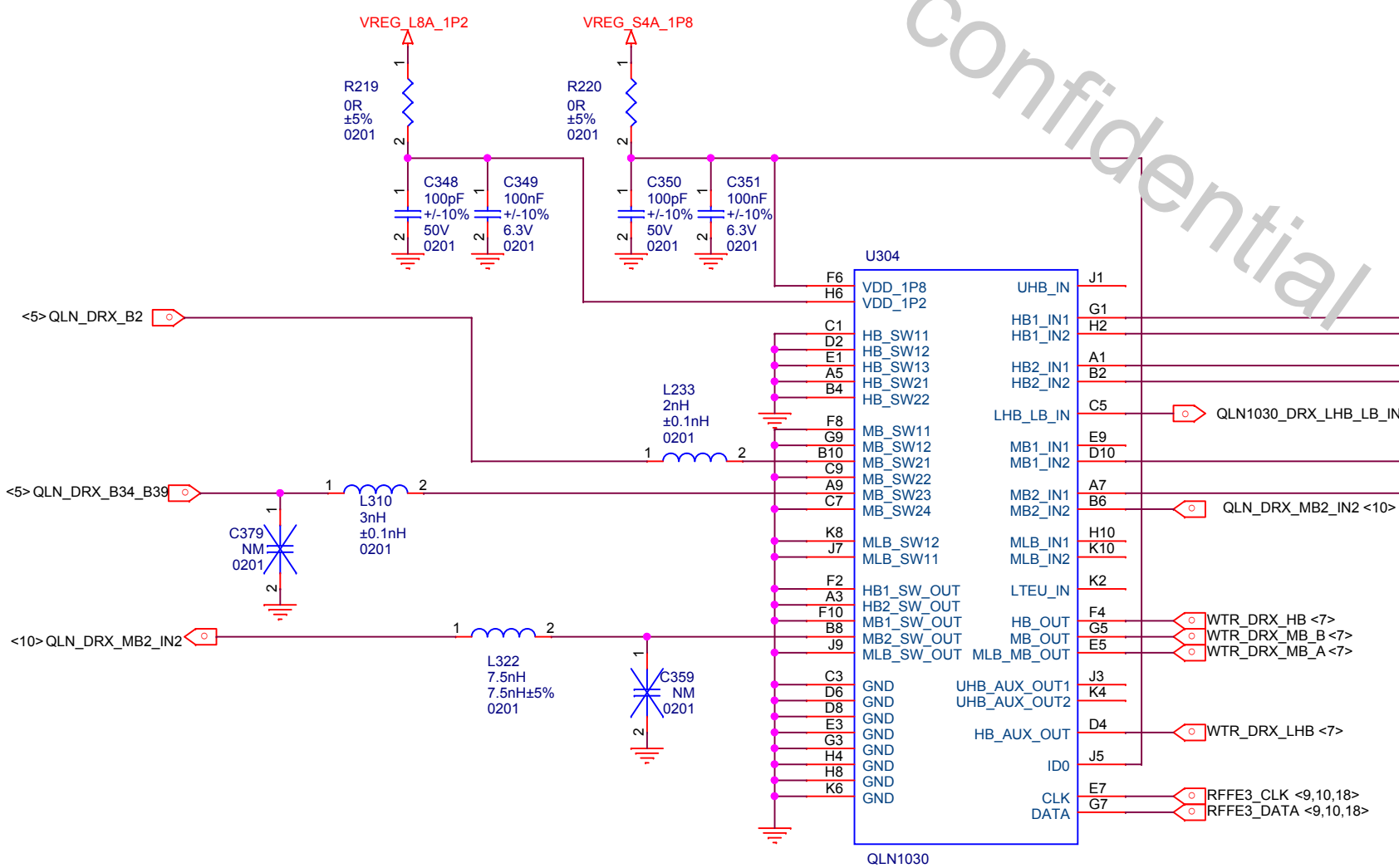

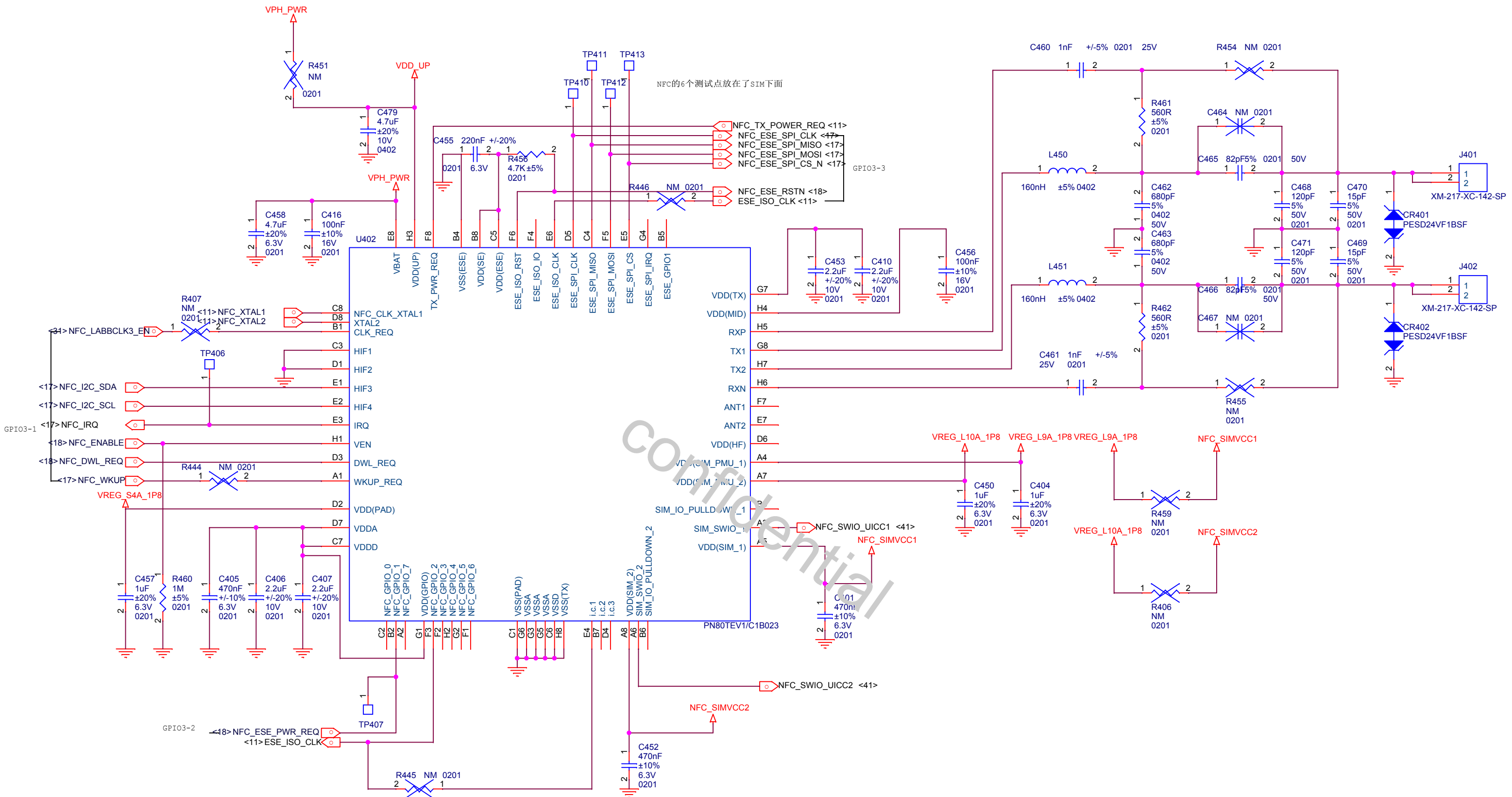

NFC的6个测试点放在了SIM下面

Confidential

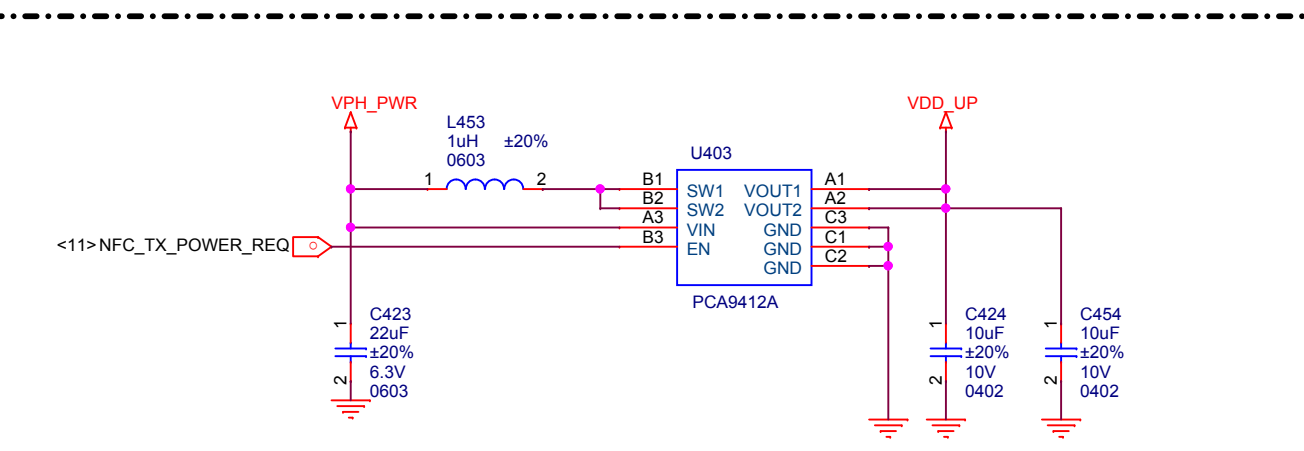
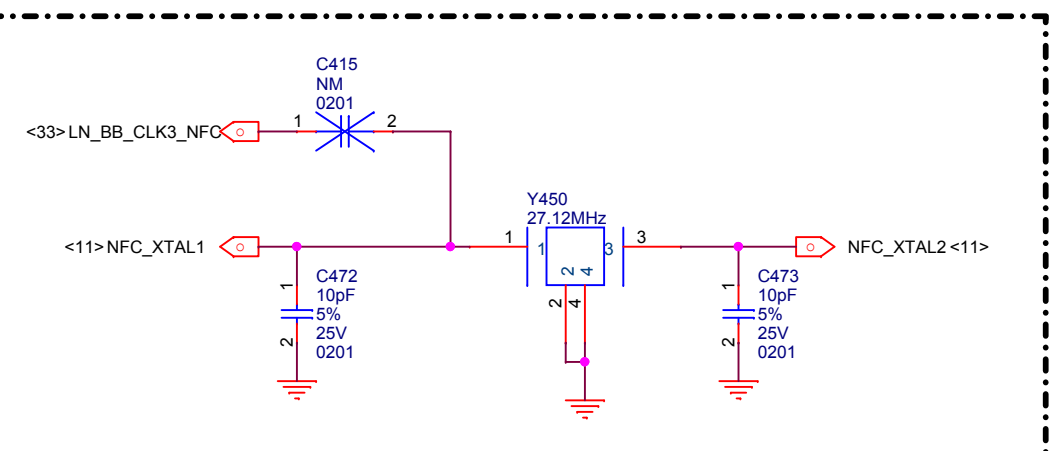

|       |                        |       |          |
|-------|------------------------|-------|----------|
| Title |                        | E8    |          |
| Size  | Document Number        | NFC   |          |
| Date: | Friday, March 23, 2018 | Sheet | 11 of 44 |
|       |                        | Rev   | P0       |

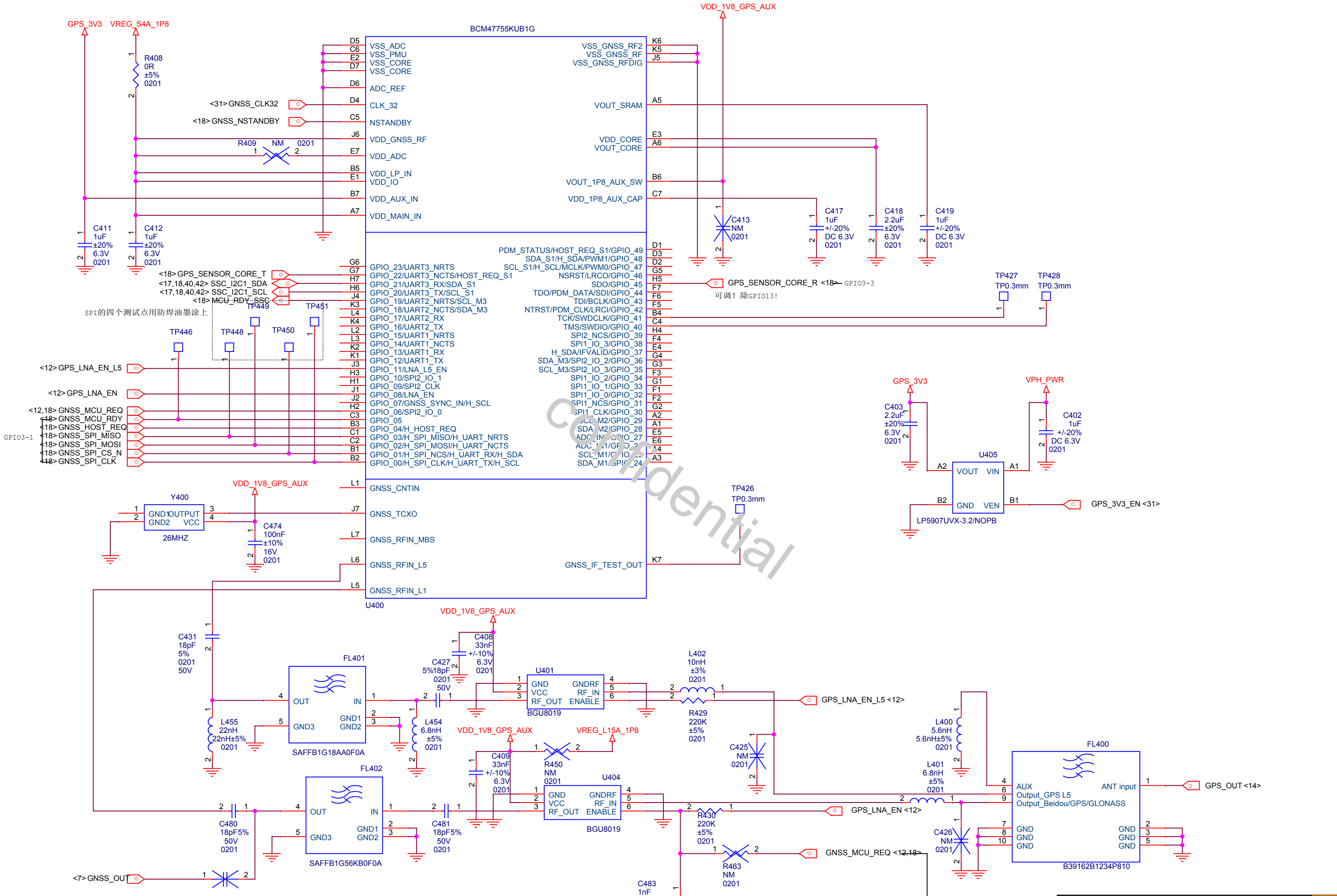

Confidential

|       |                        |               |          |
|-------|------------------------|---------------|----------|
| Title |                        | E8            |          |
| Size  | Document Number        | Dual-band GPS |          |
| Date: | Friday, March 23, 2018 | Sheet         | 12 of 44 |

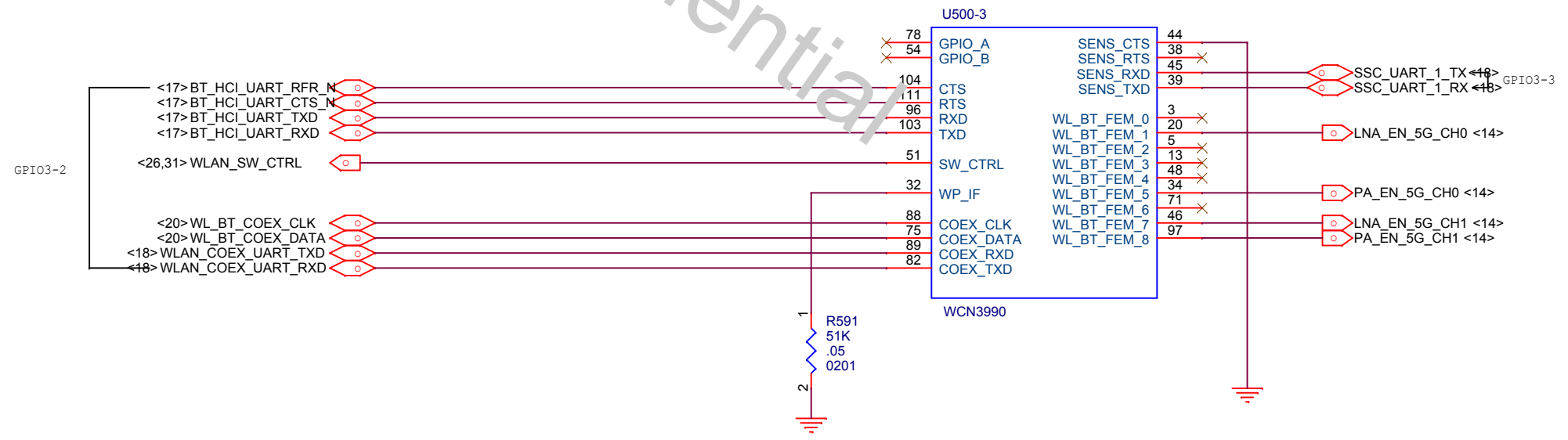
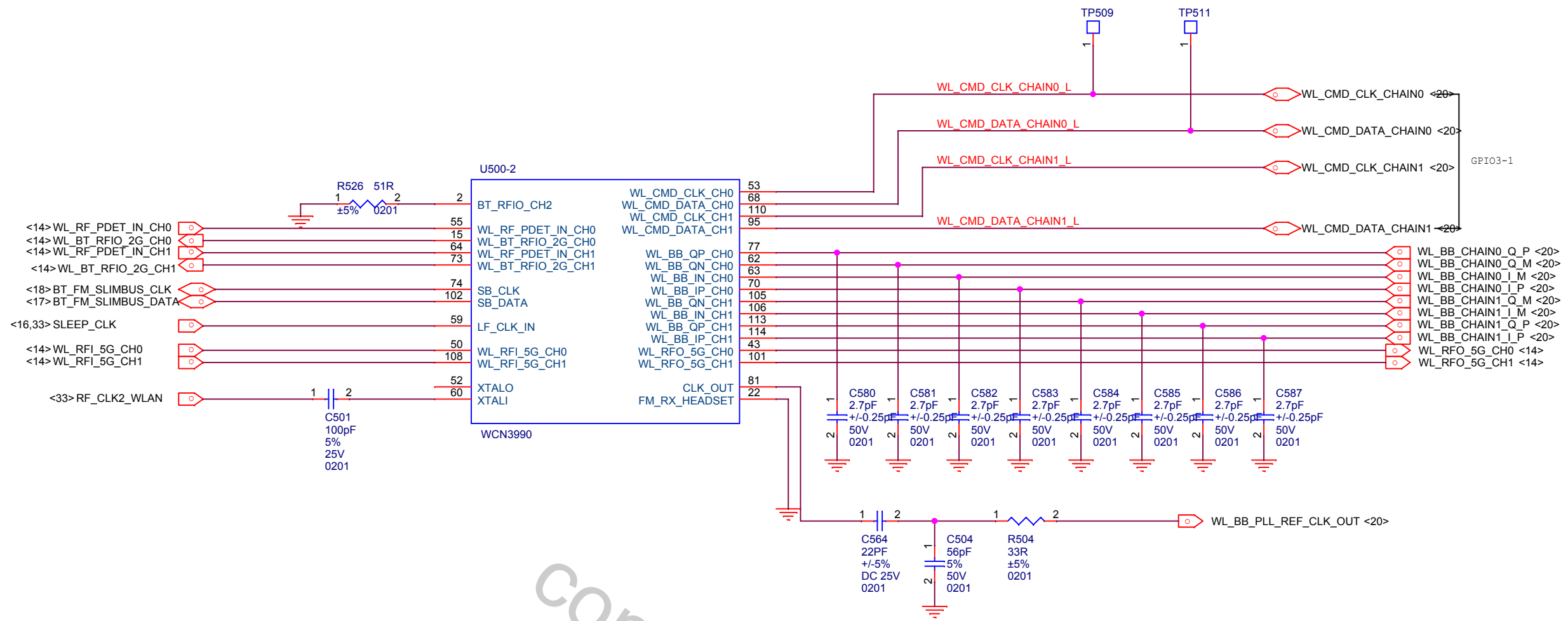

Confidential

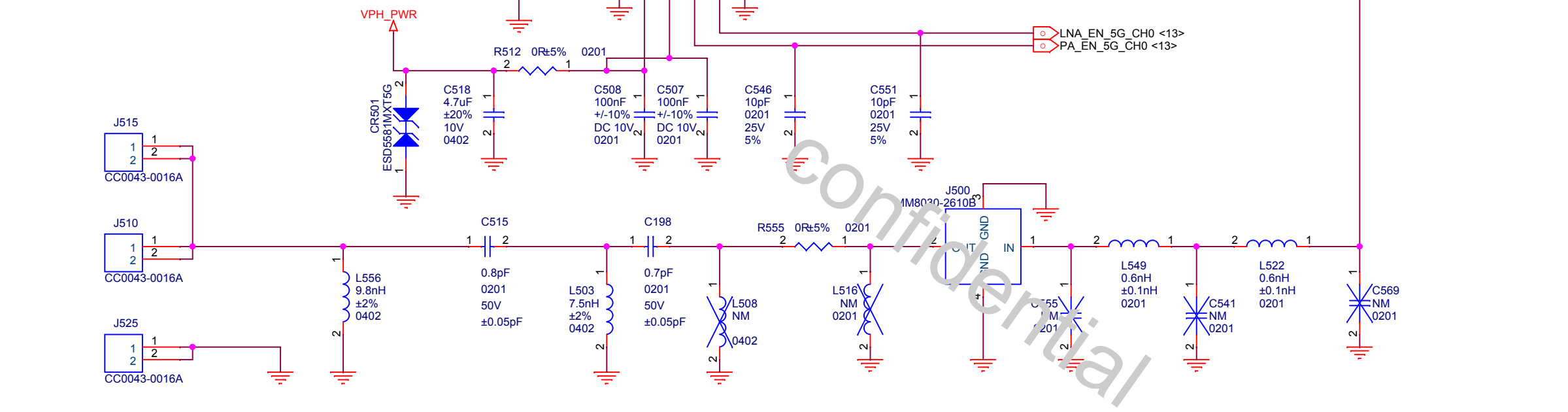
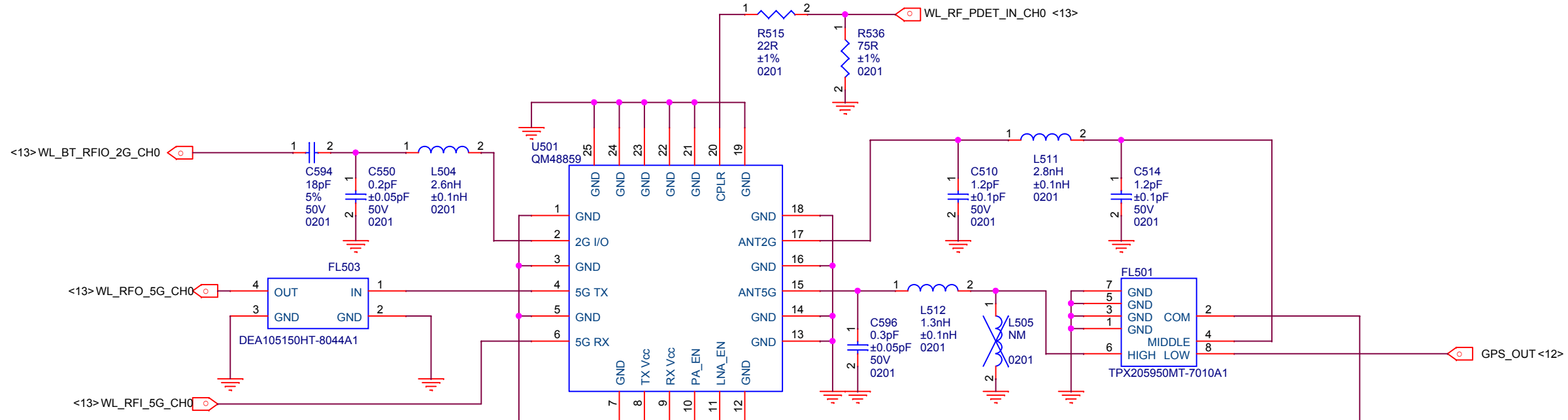



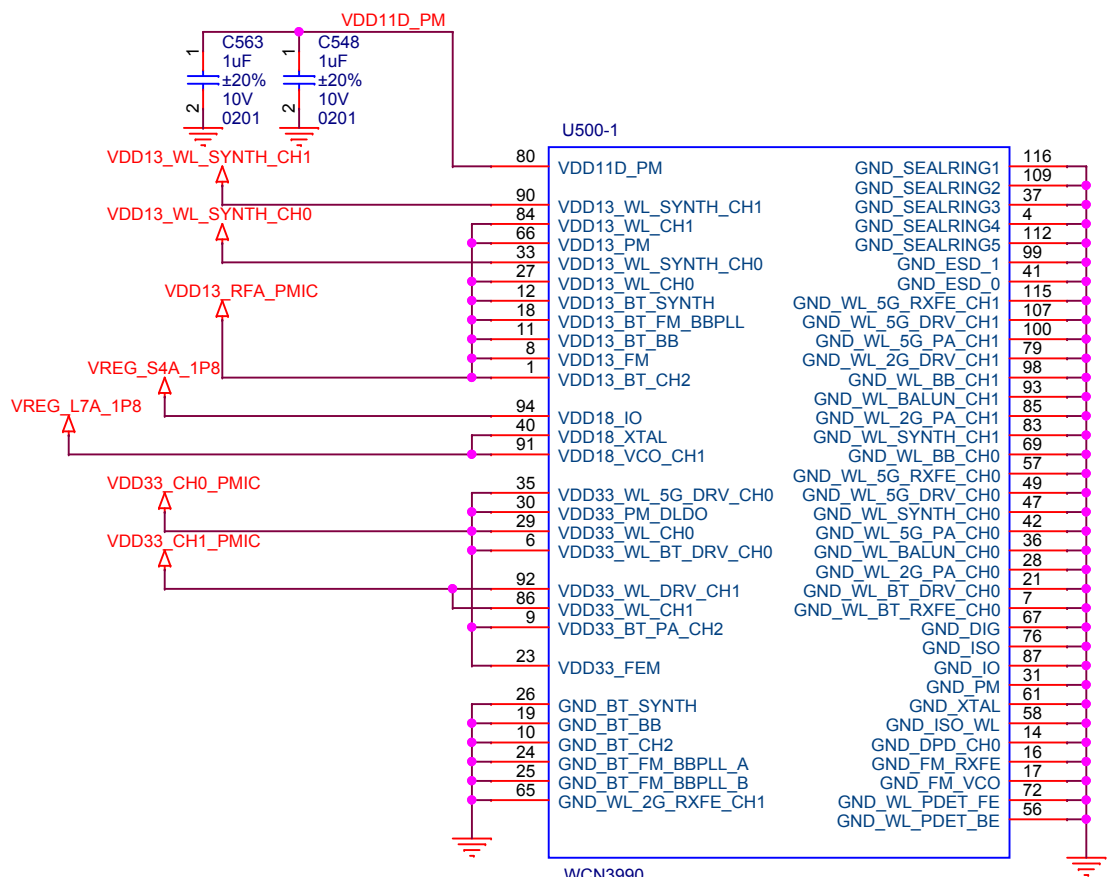
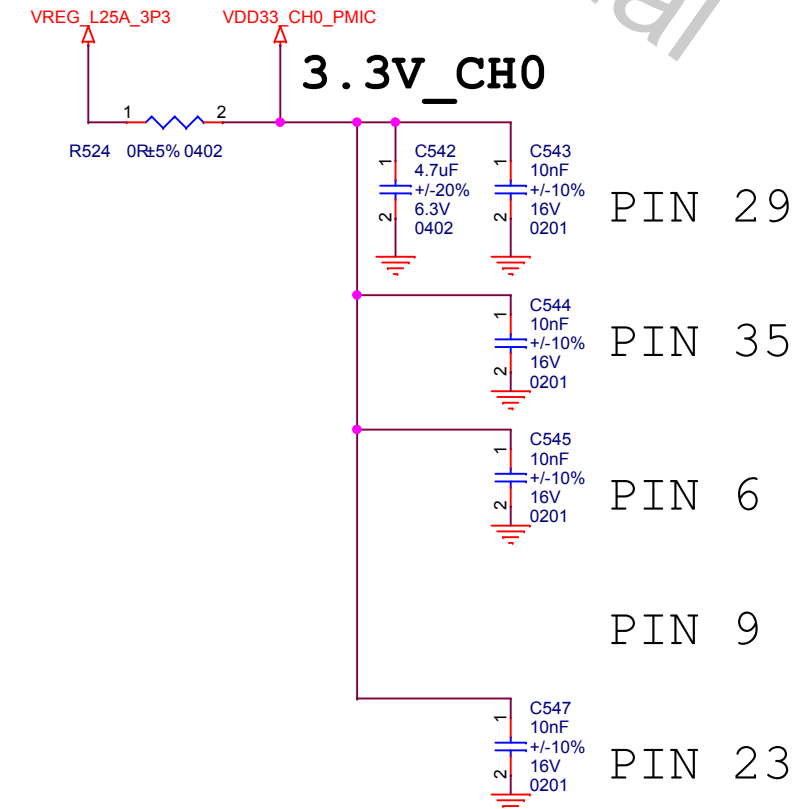
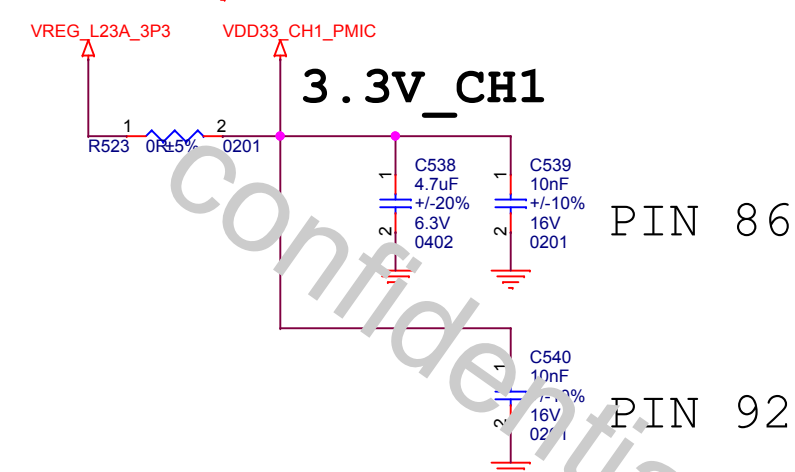
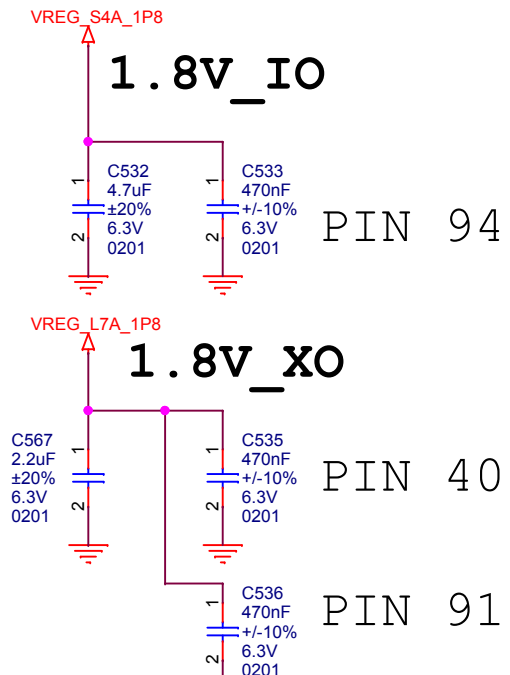
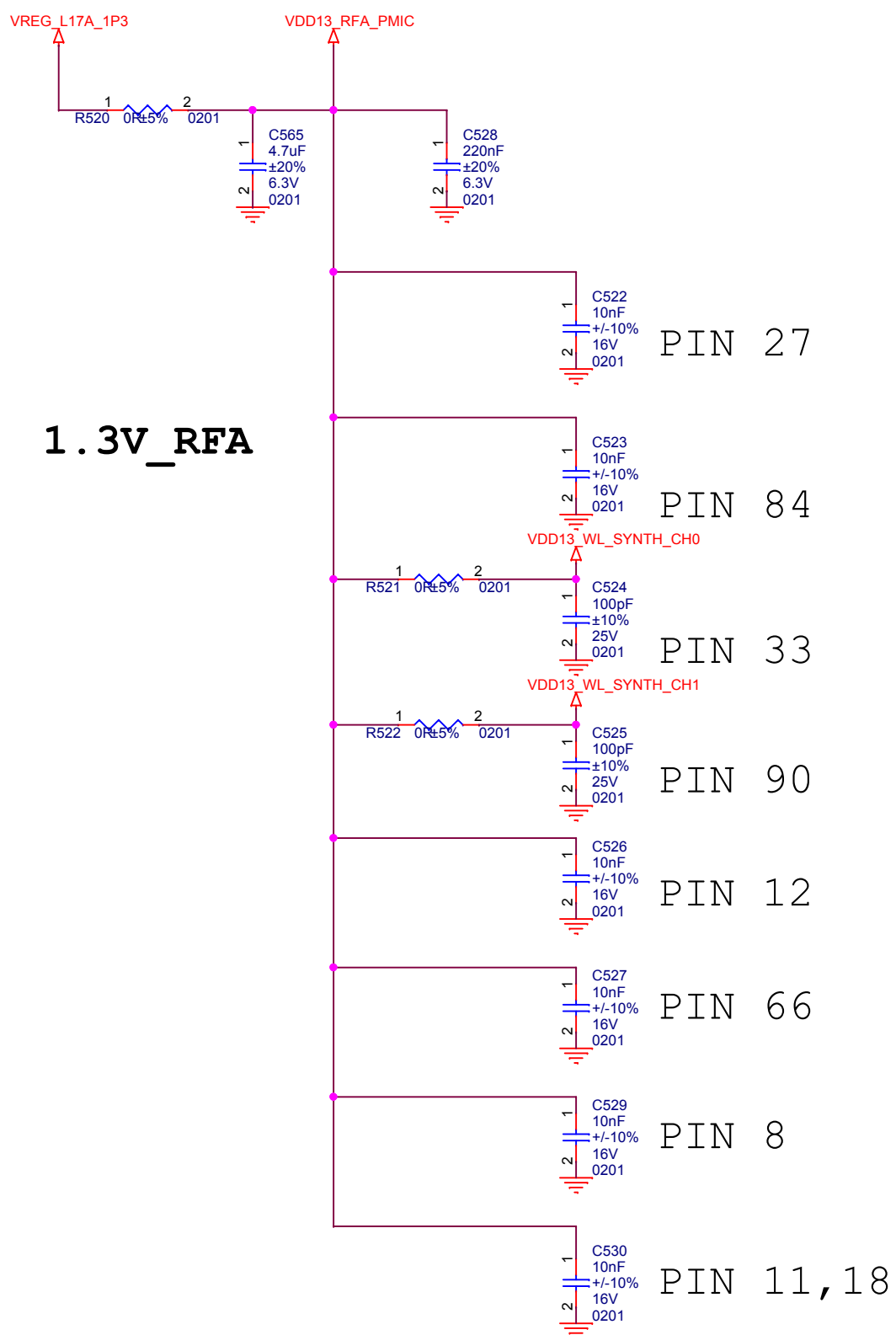

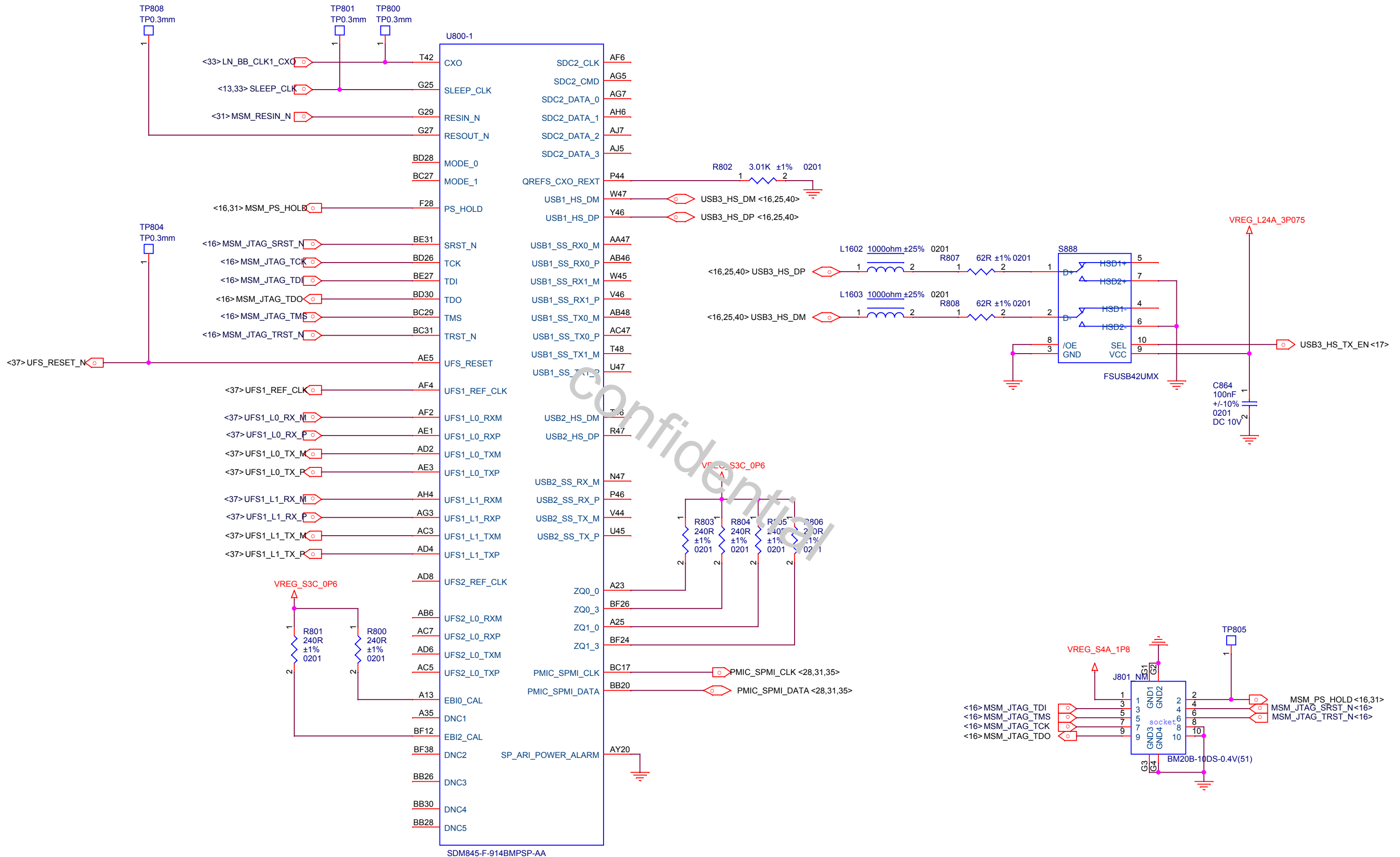

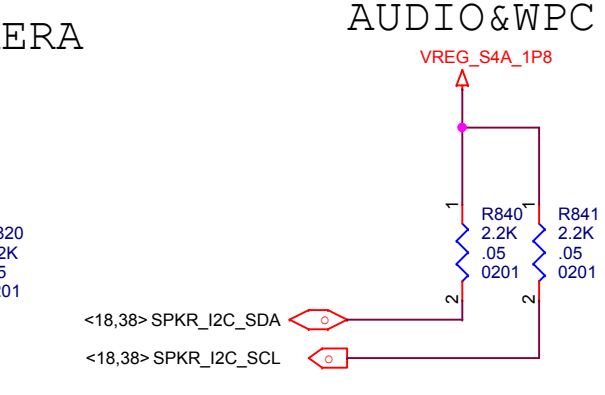
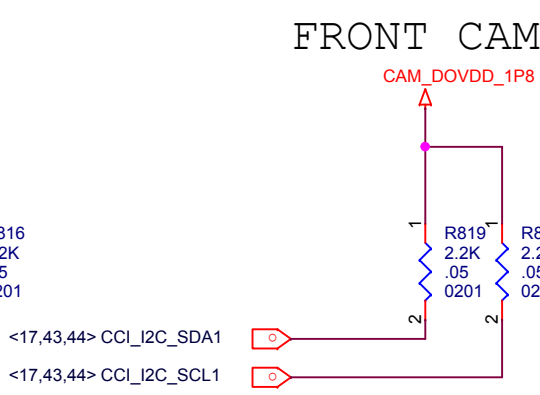
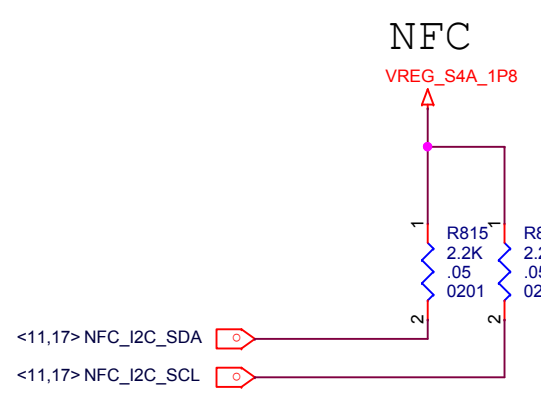
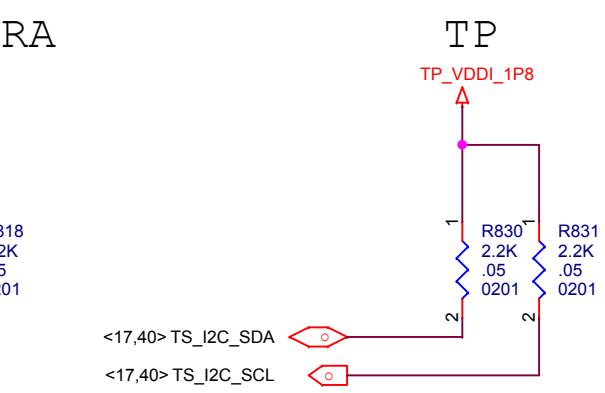
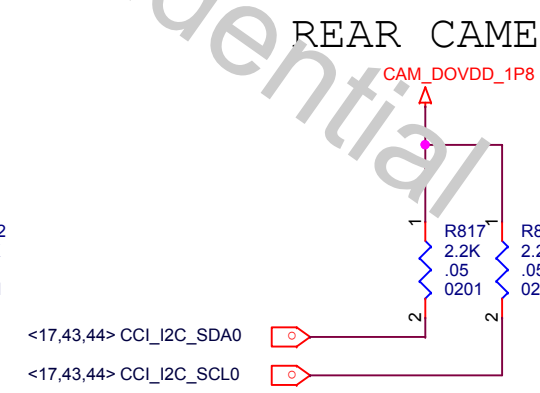
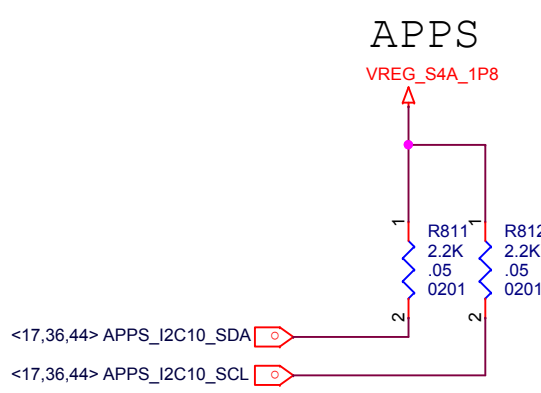
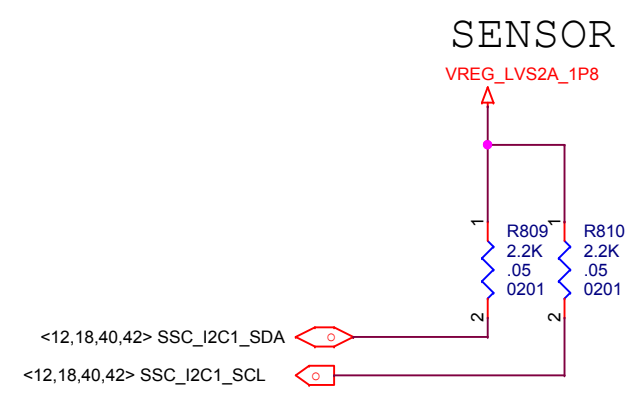
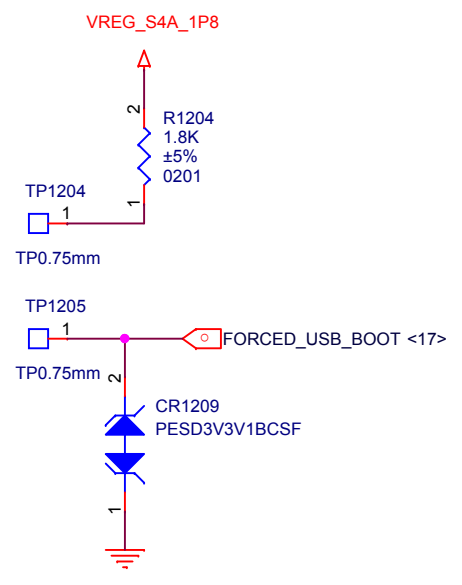
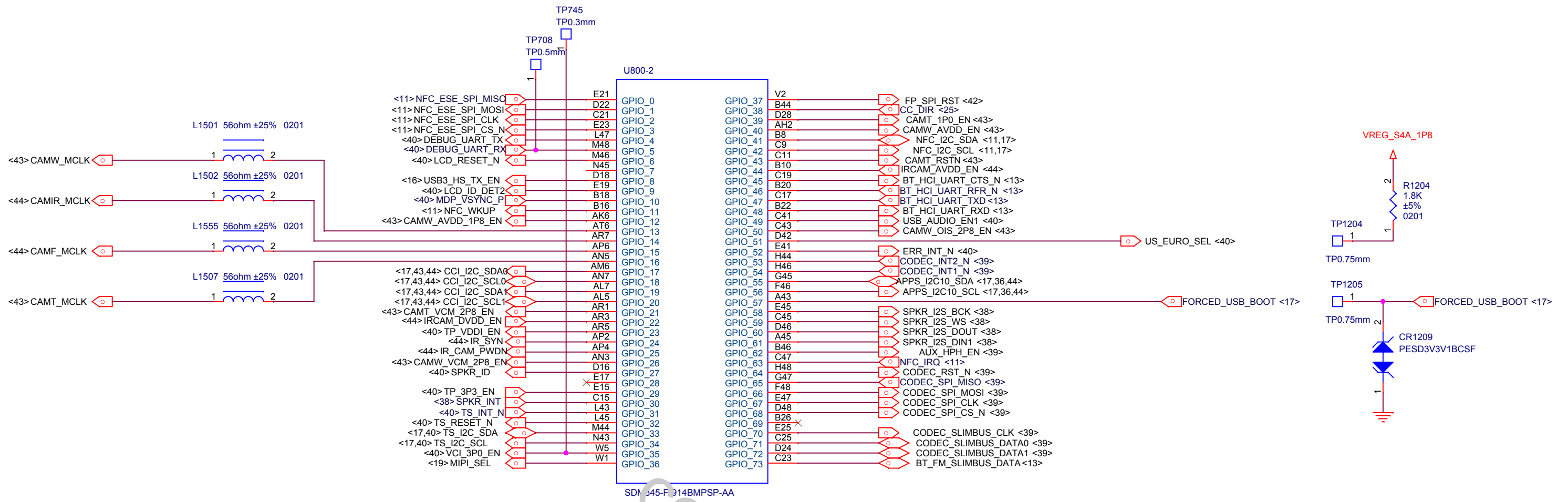

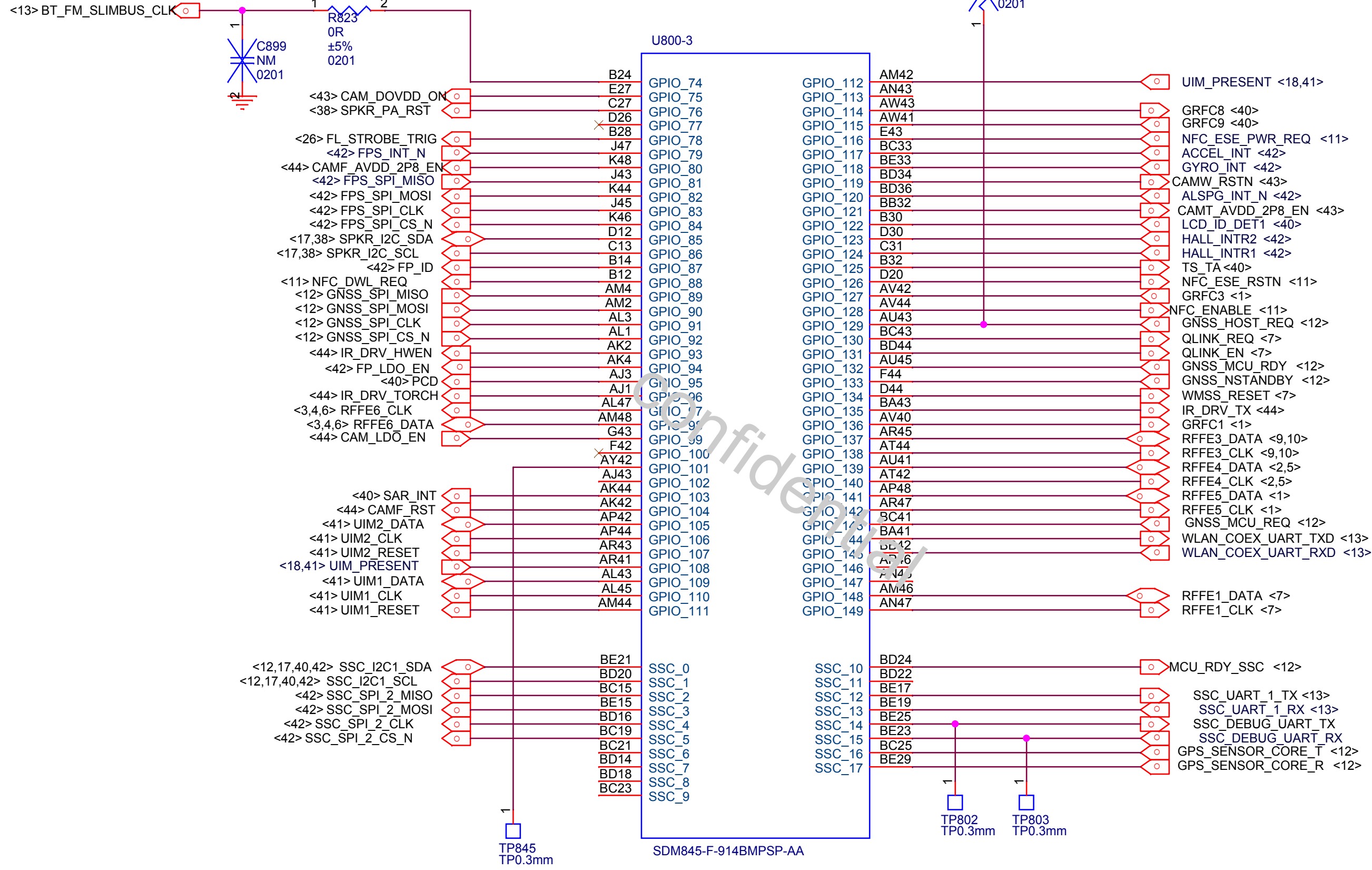

REAR CAMERA WIDE

REAR CAMERA TELE

FRONT CAMERA

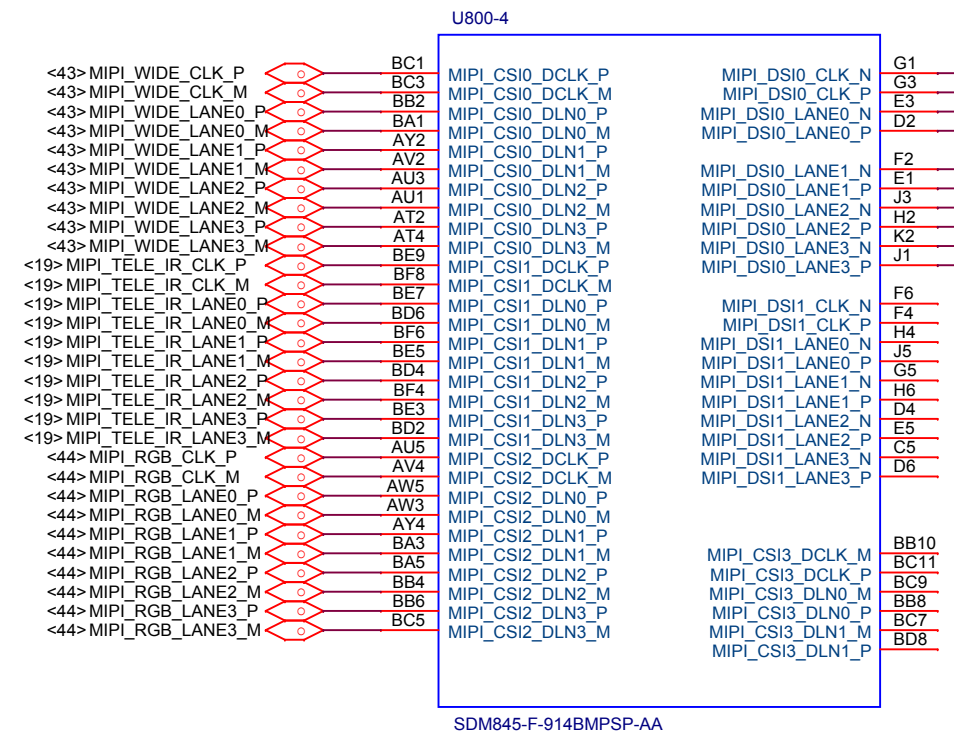

SDM845-F-914BMPSP-AA

DISPLAY

U800-5

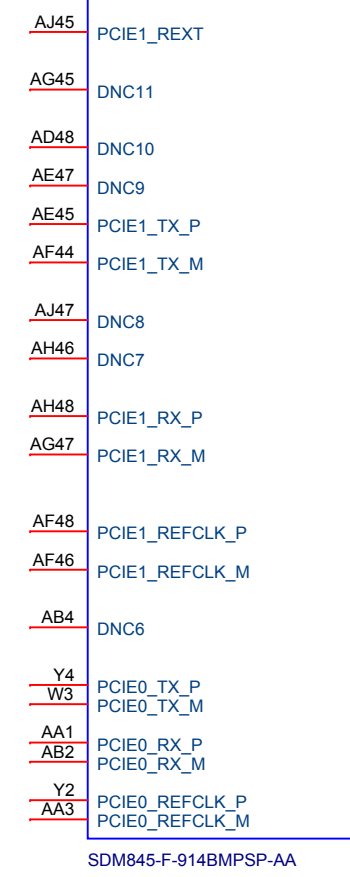

SDM845-F-914BMPSP-AA

TELE-IR SWITCH

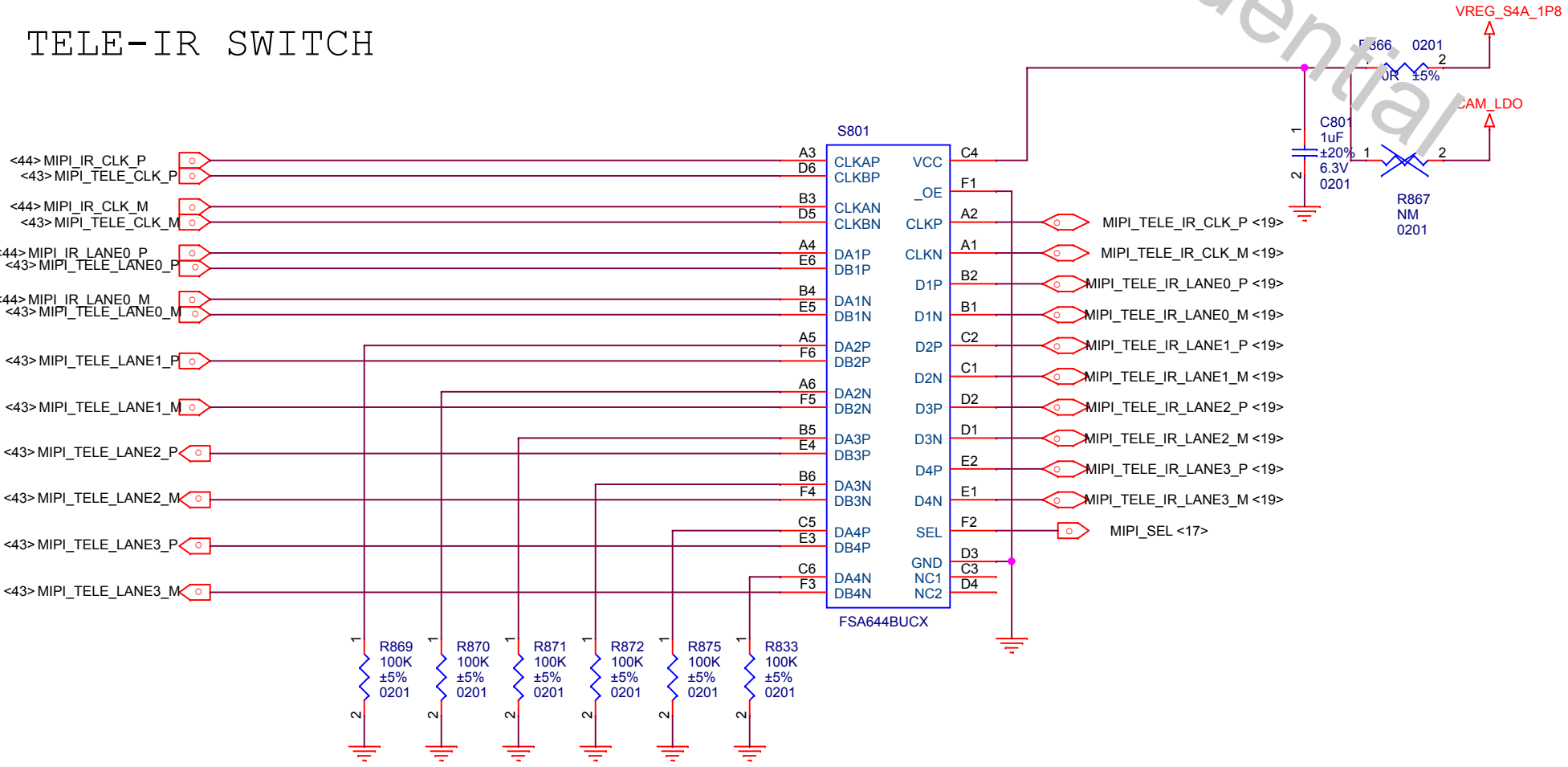

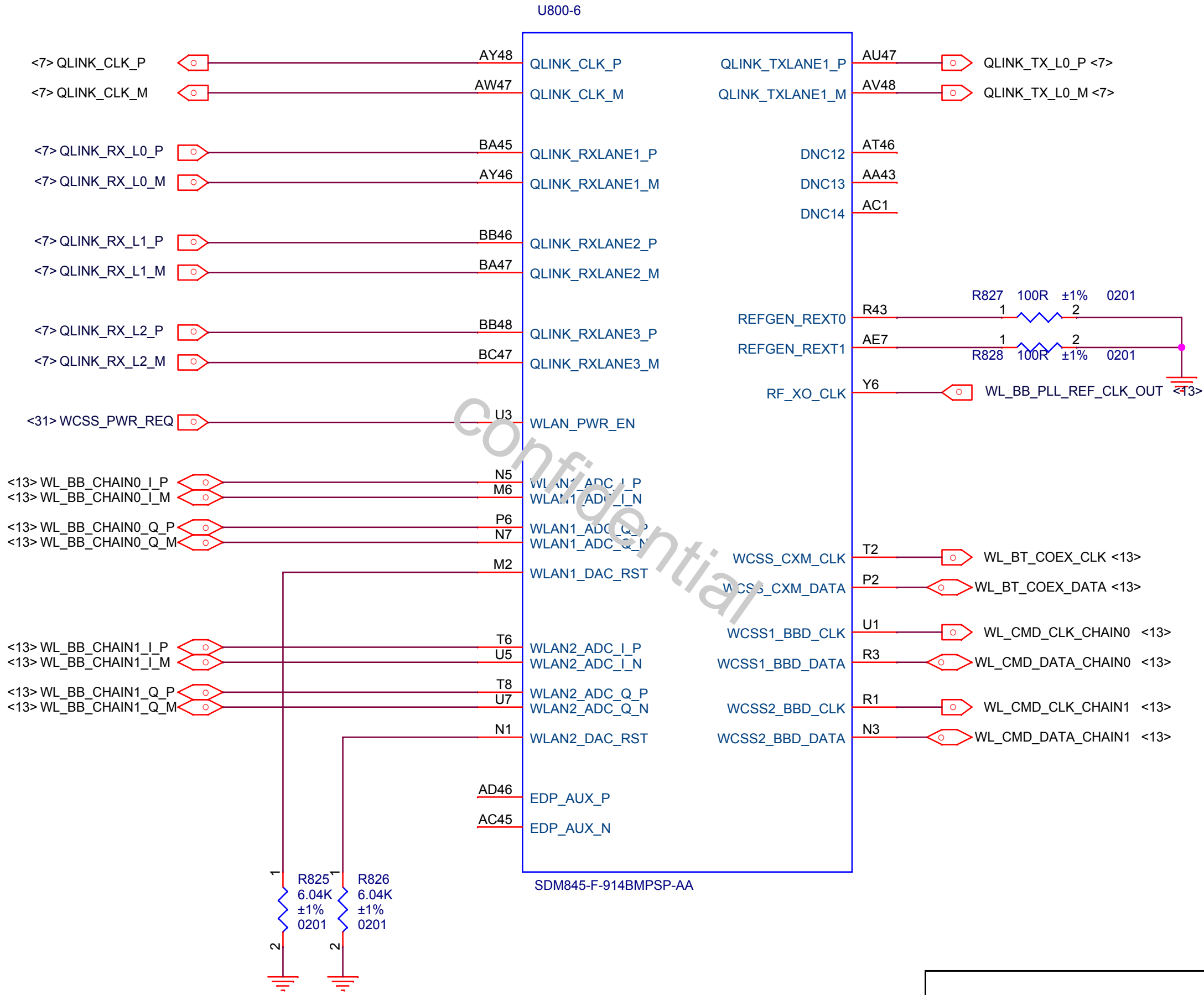

|       |                        |       |          |
|-------|------------------------|-------|----------|
| Title |                        | E8    |          |
| Size  | Document Number        |       |          |
| A4    | SDM845 RF INTF         | Rev   | P0       |
| Date: | Friday, March 23, 2018 | Sheet | 20 of 44 |

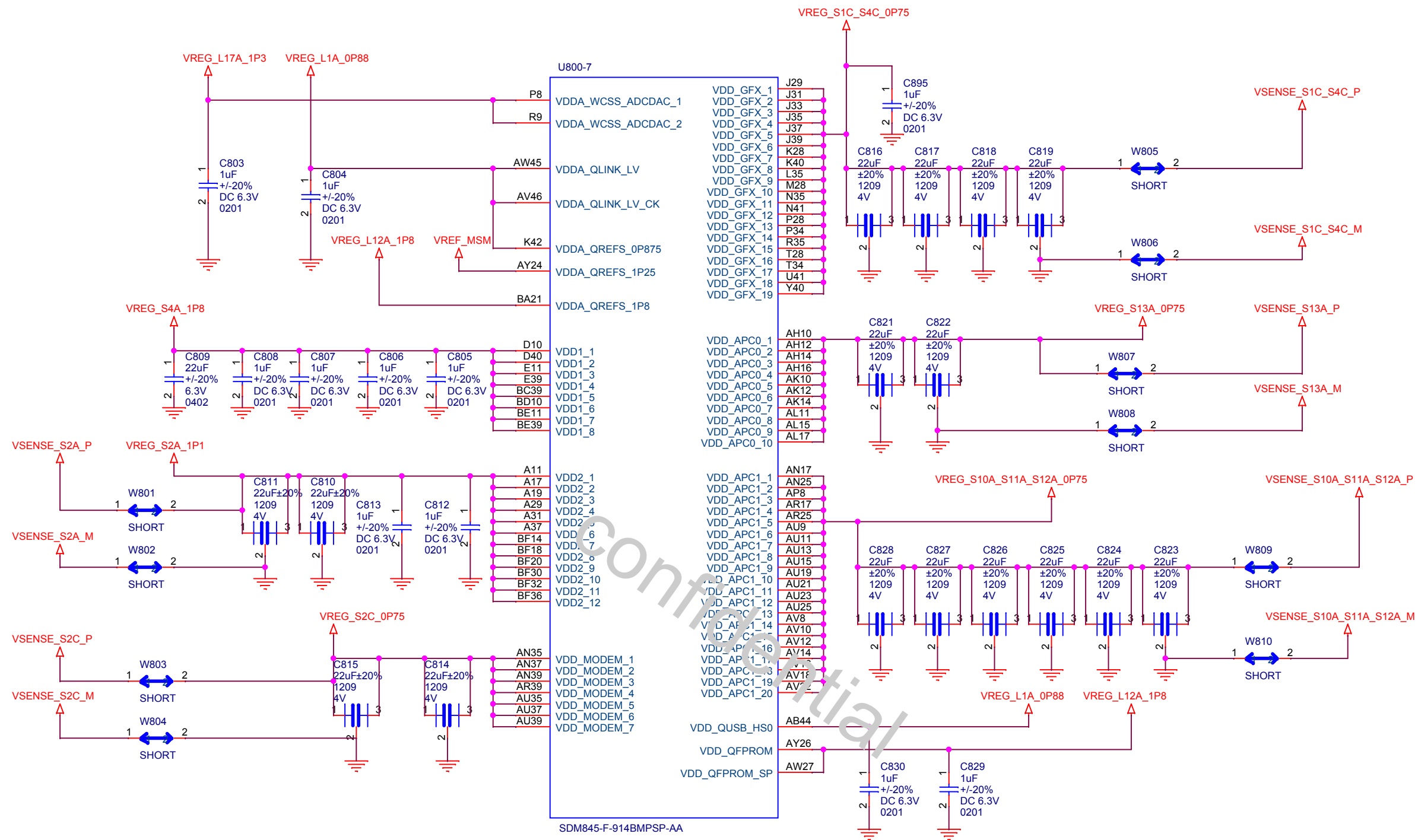

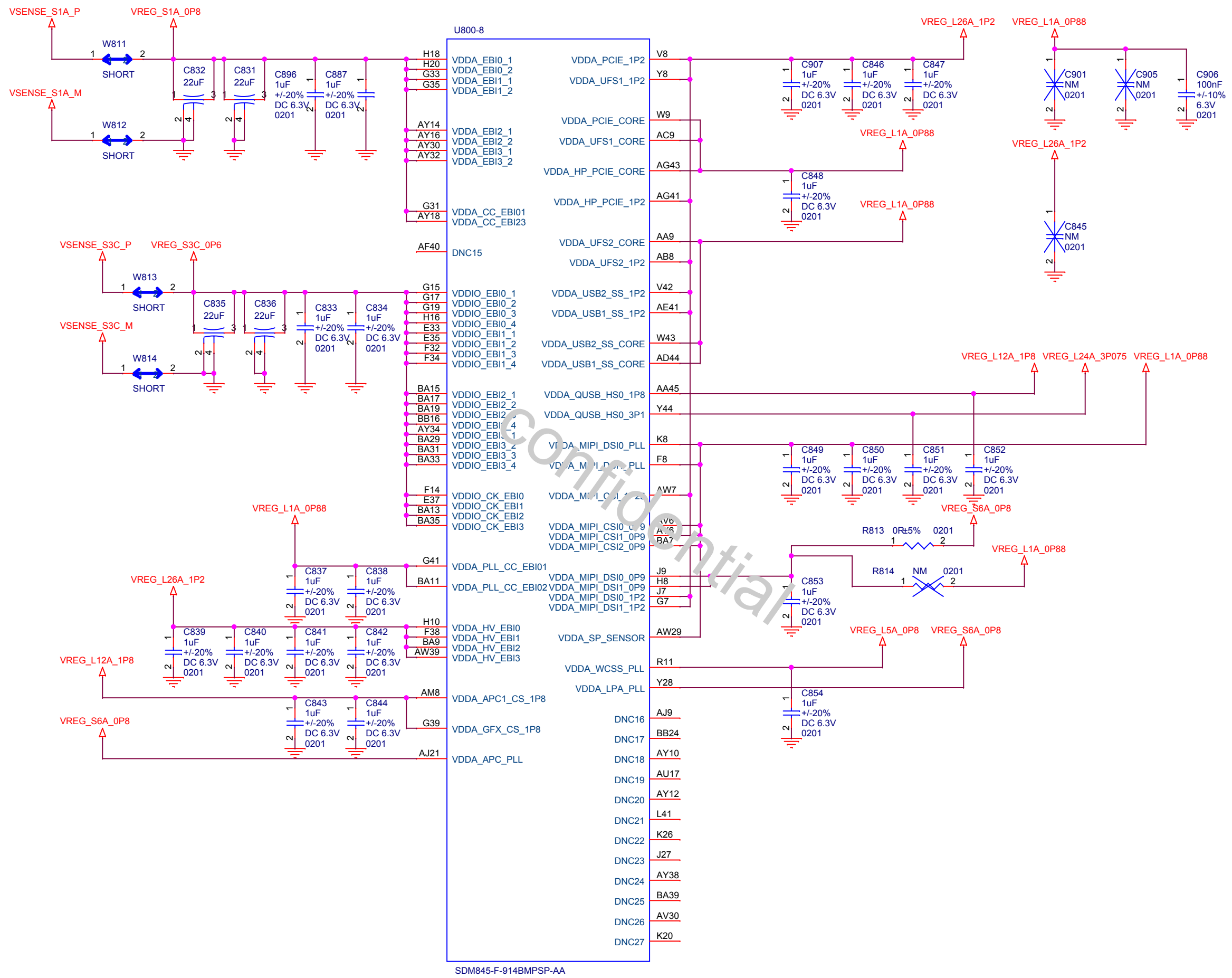



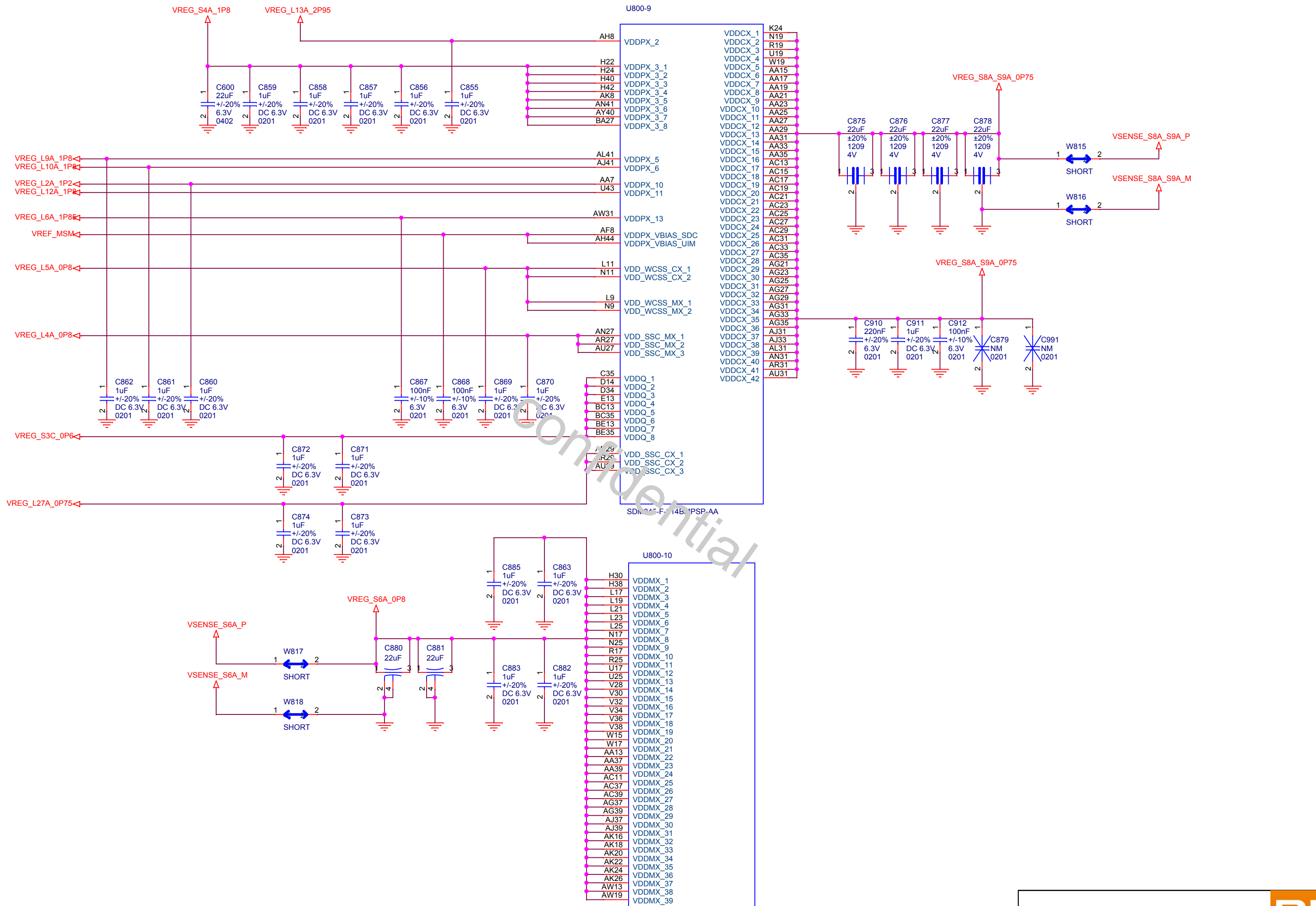

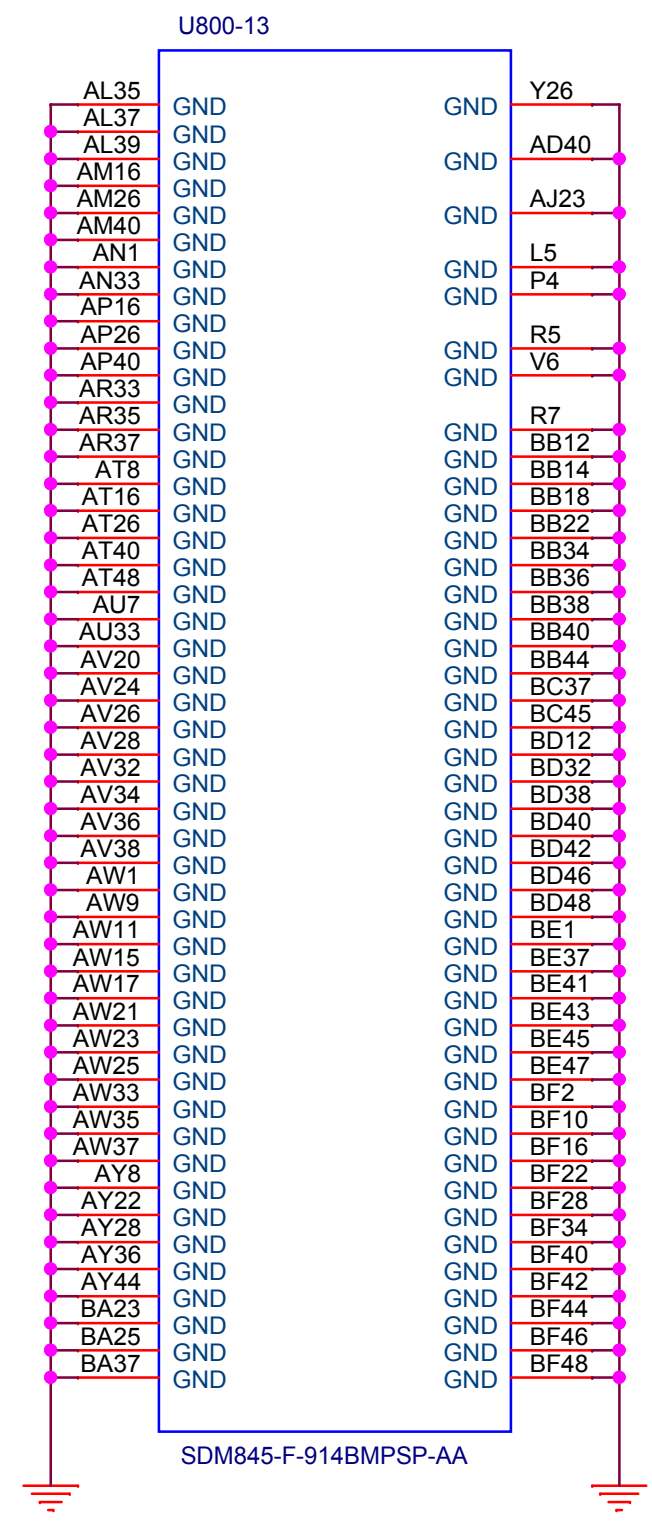
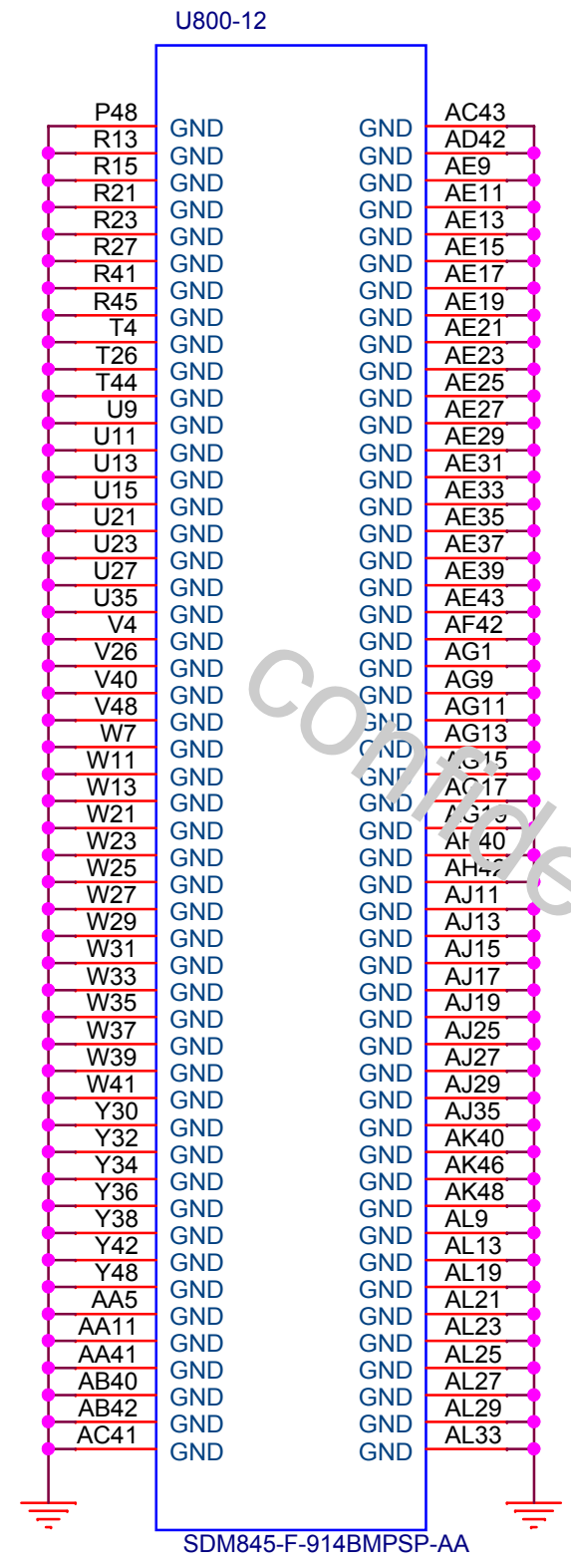
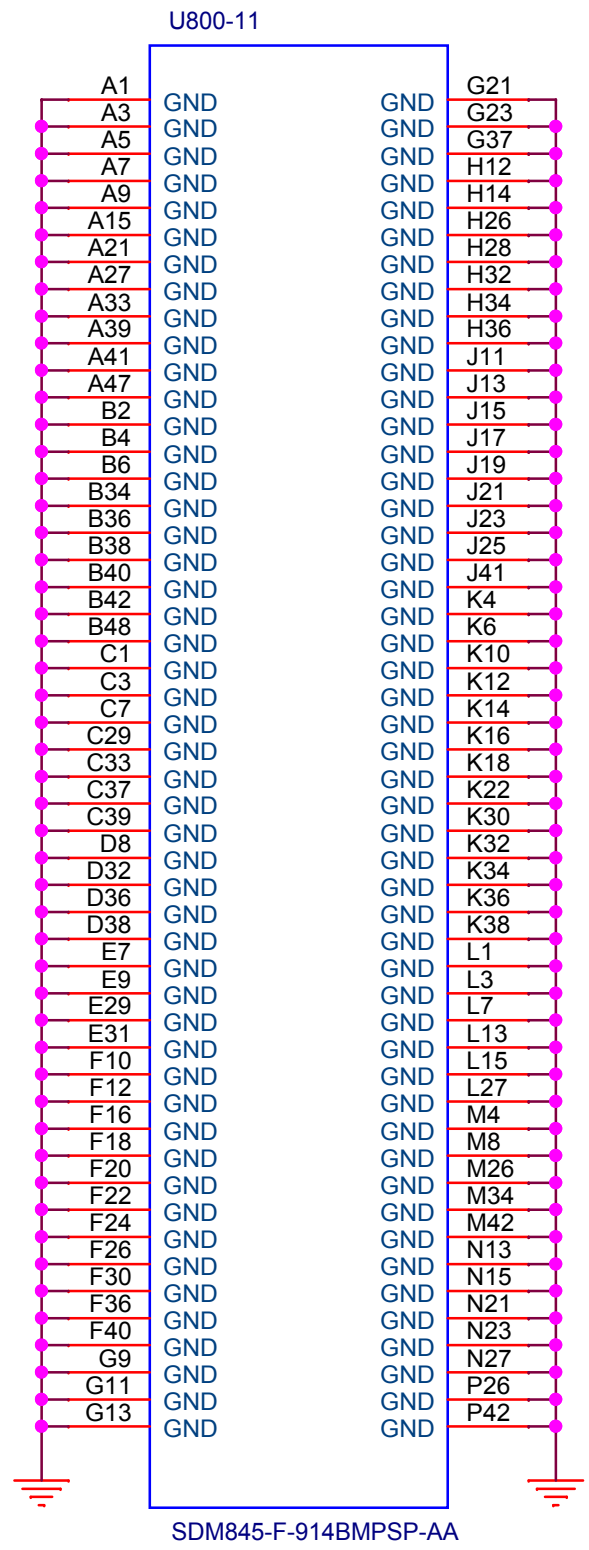

# PMI8998

# VCONN

# BATTERY

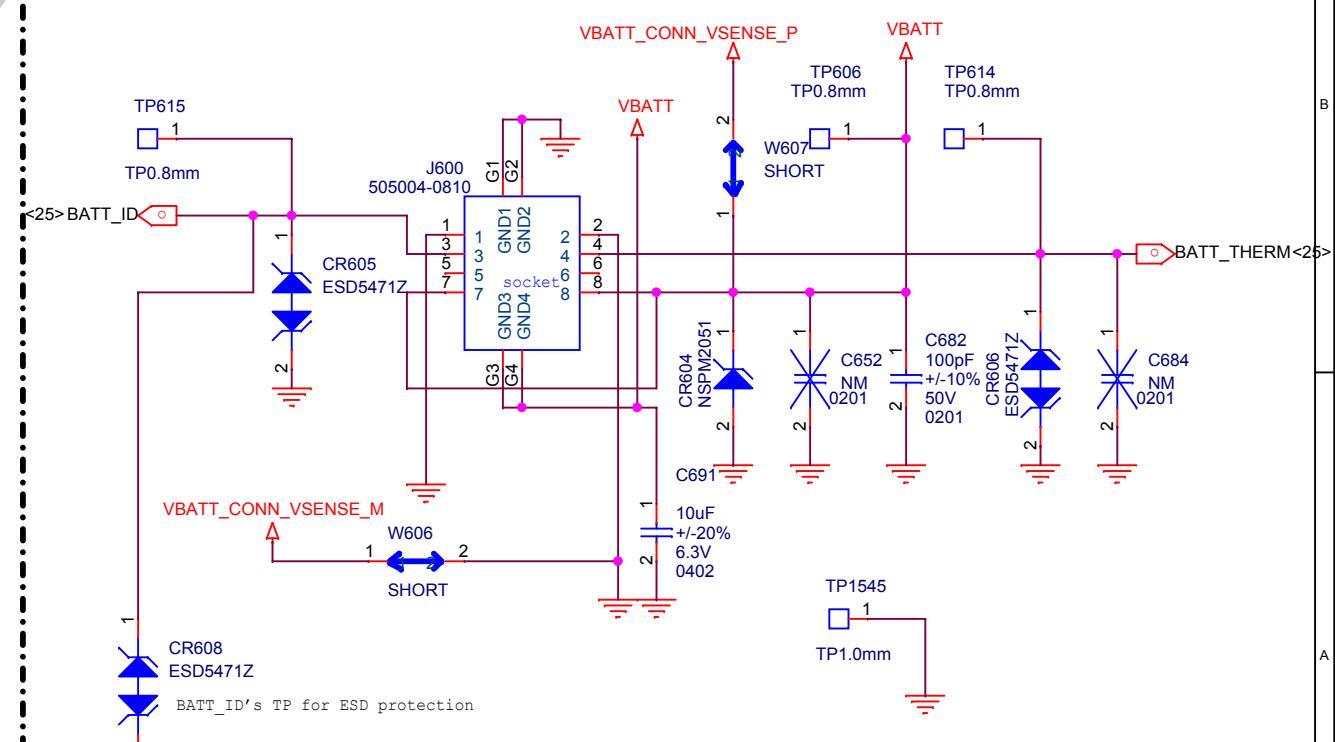
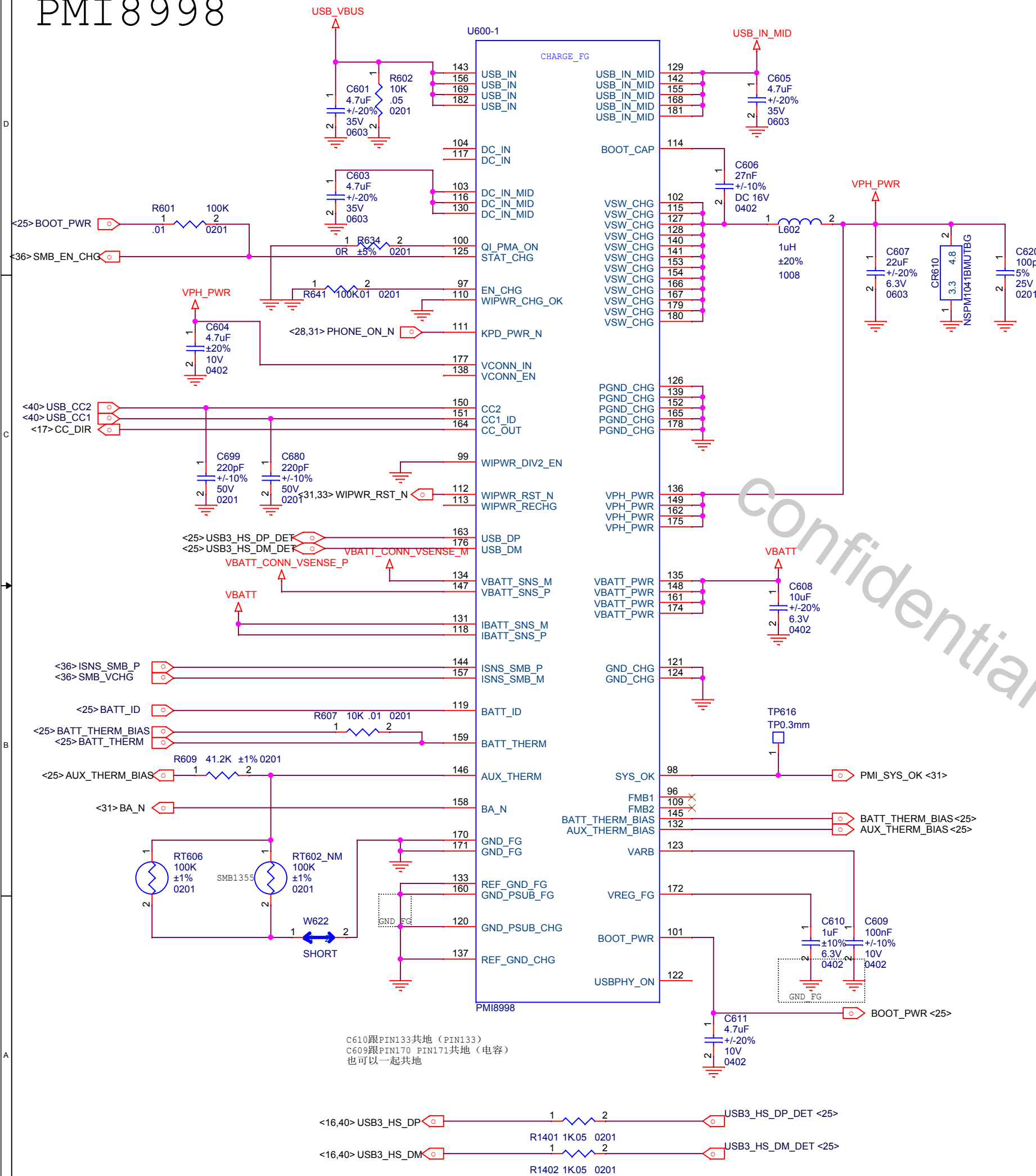



|       |                        |                 |                |
|-------|------------------------|-----------------|----------------|
| Title |                        | E8              |                |
| Size  | A3                     | Document Number | PIM8998 CHARGE |
| Date: | Friday, March 23, 2018 | Sheet           | 25 of 44       |
|       |                        | Rev P0          |                |

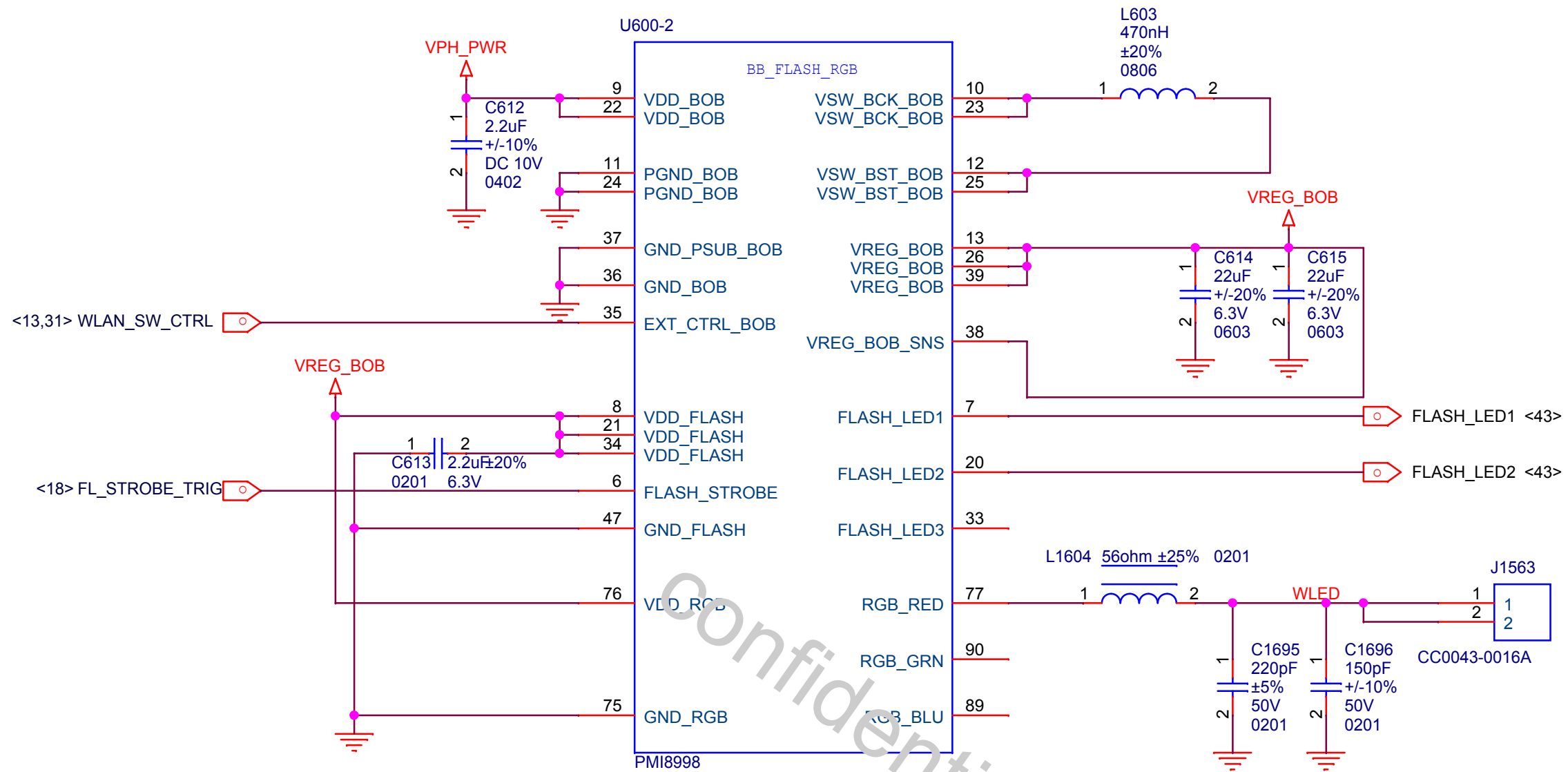



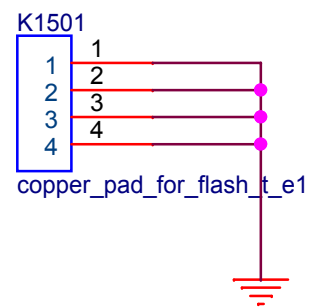

# FLASH Board

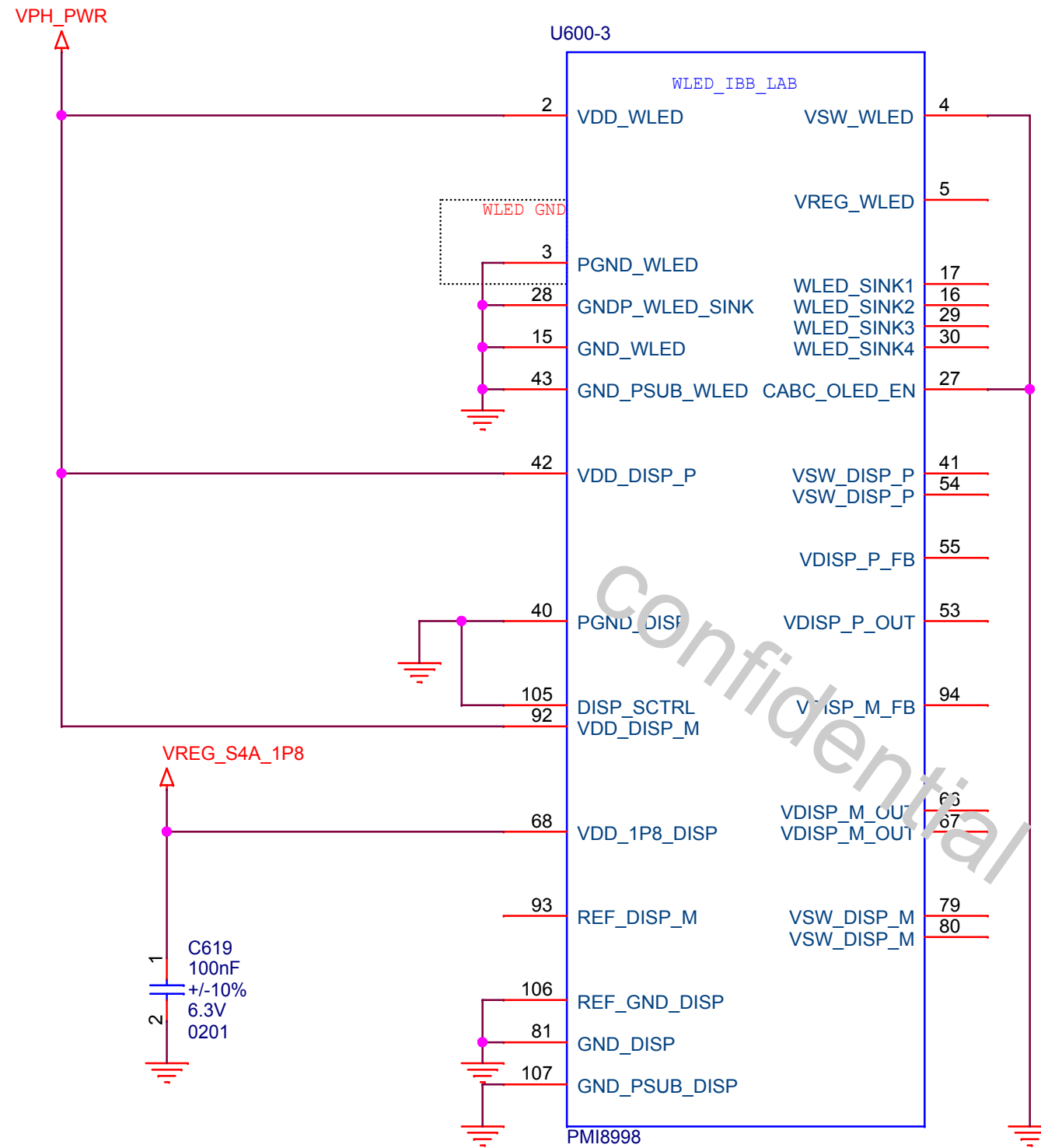

|       |                        |       |   |
|-------|------------------------|-------|---|
| Title |                        | E8    |  |
| Size  | Document Number        |       |   |
| A4    | PMI8998 FLASH RGB      | Rev   | P0  |
| Date: | Friday, March 23, 2018 | Sheet | 26 of 44  |



|       |                        |                      |          |   |
|-------|------------------------|----------------------|----------|---|
| Title |                        | E8                   |          |  |
| Size  | Document Number        | PMI8998 WLED IBB LAB |          |   |
| A4    |                        |                      |          | P0  |
| Date: | Friday, March 23, 2018 | Sheet                | 27 of 44 |   |

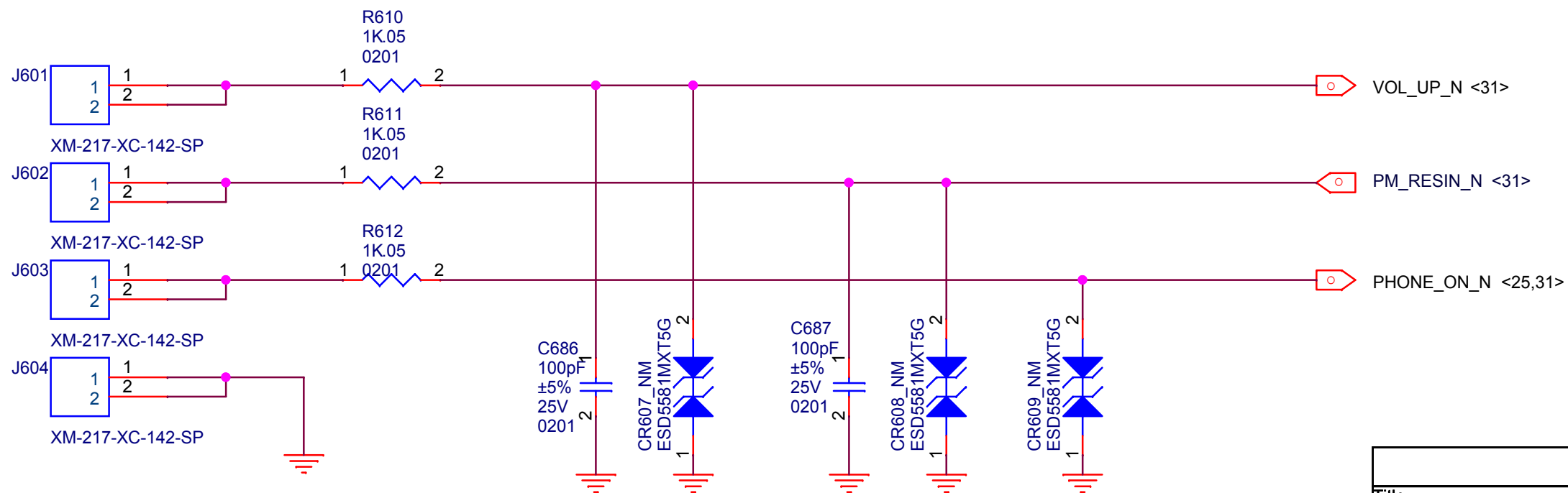
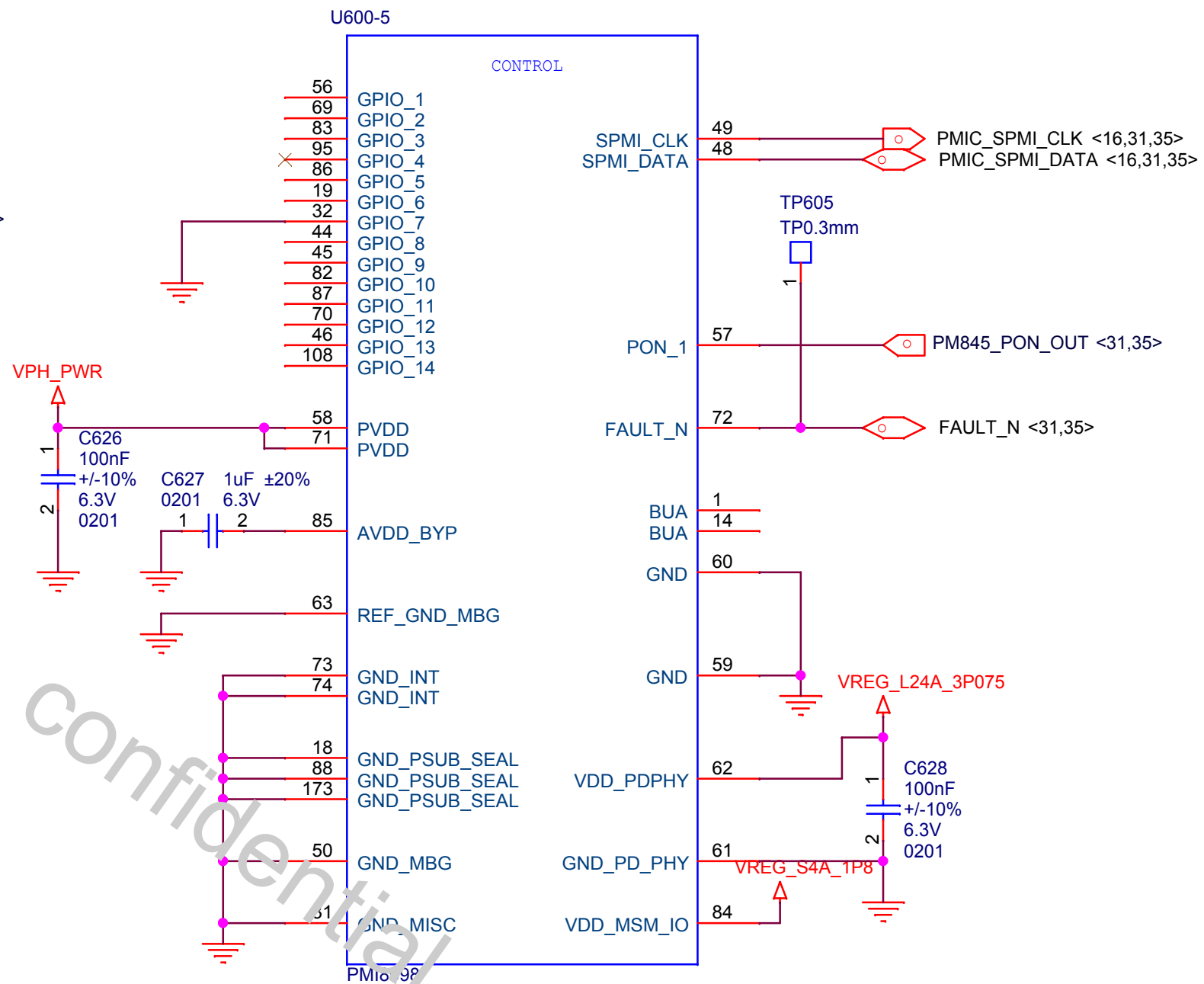
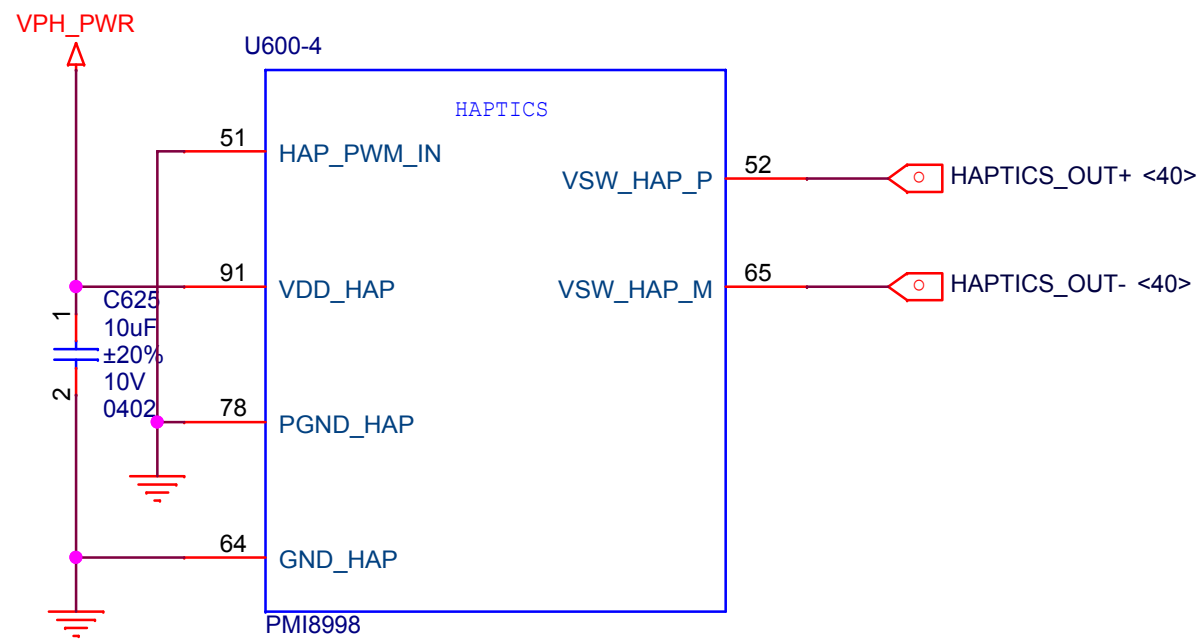

|       |                        |                 |                         |    |     |
|-------|------------------------|-----------------|-------------------------|----|-----|
| Title |                        | E8              |                         |    |     |
| Size  | A4                     | Document Number | PMI8998 HAPTICS&SIDEKEY |    | Rev |
| Date: | Friday, March 23, 2018 | Sheet           | 28                      | of | 44  |

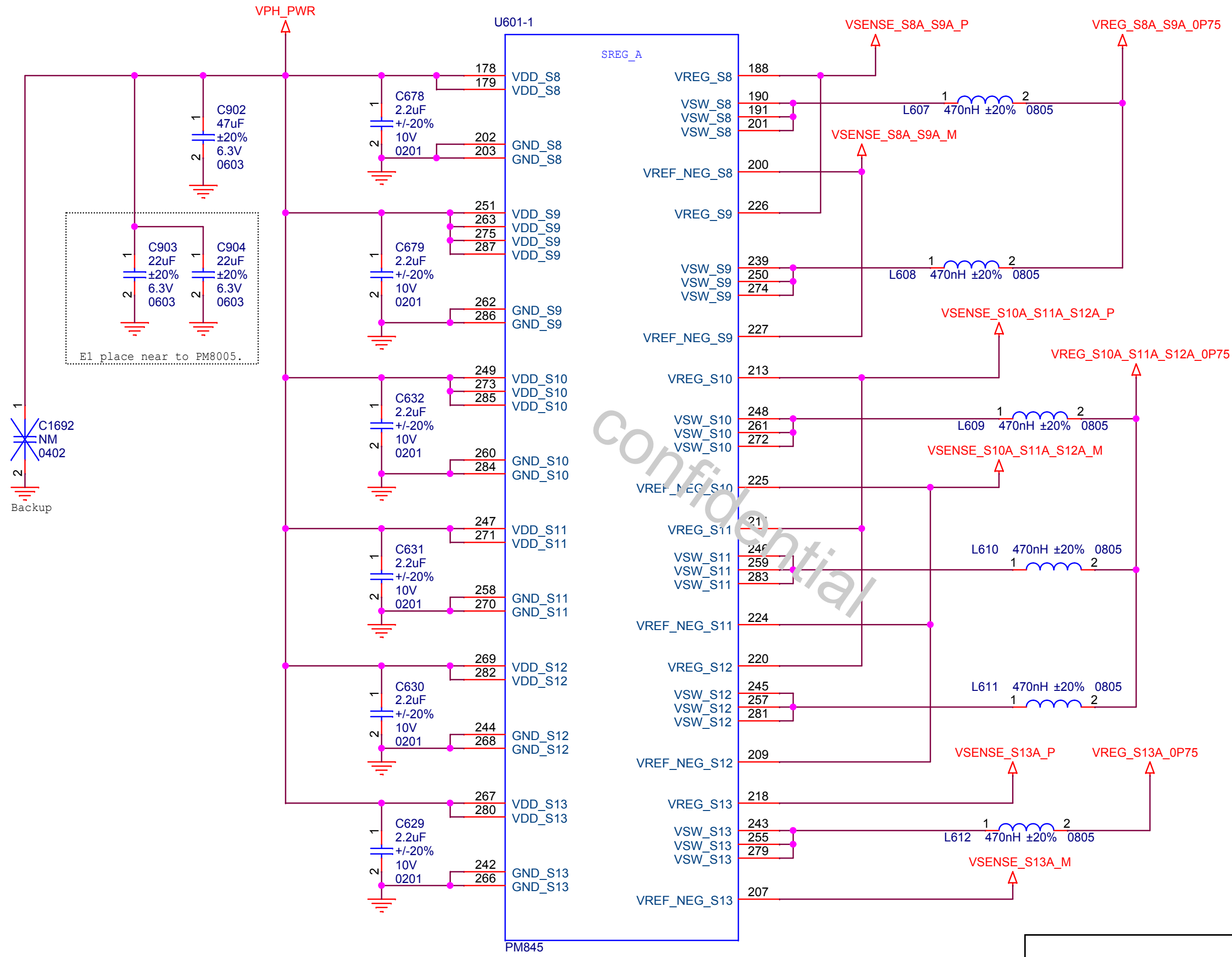

|       |                        |                 |              |   |     |
|-------|------------------------|-----------------|--------------|---|-----|
| Title |                        | E8              |              |  |     |
| Size  | A4                     | Document Number | PM845 SREG A |   | Rev |
| Date: | Friday, March 23, 2018 | Sheet           | 29           | of  | 44  |
|       |                        |                 |              | Rev   | P0  |

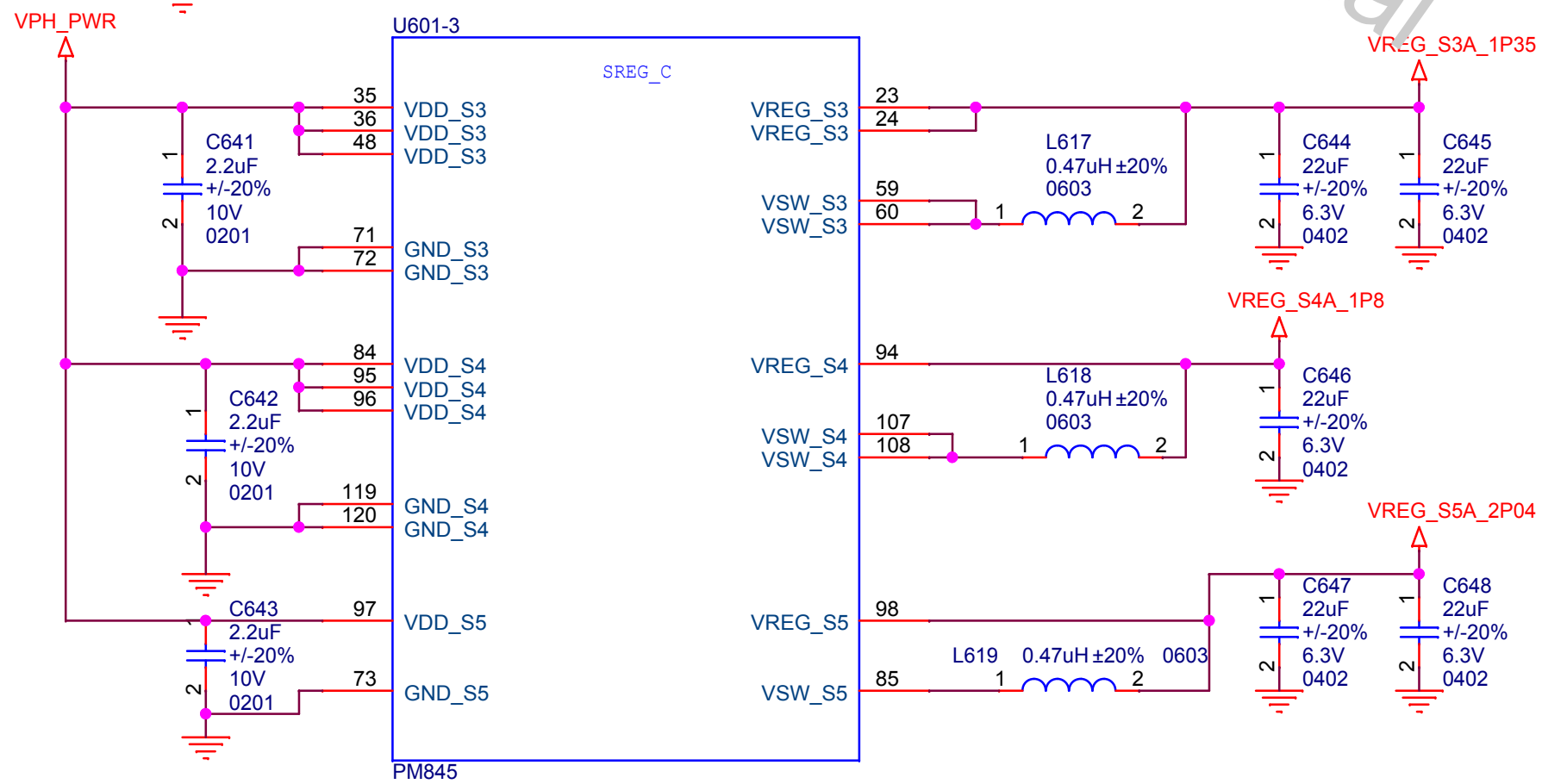
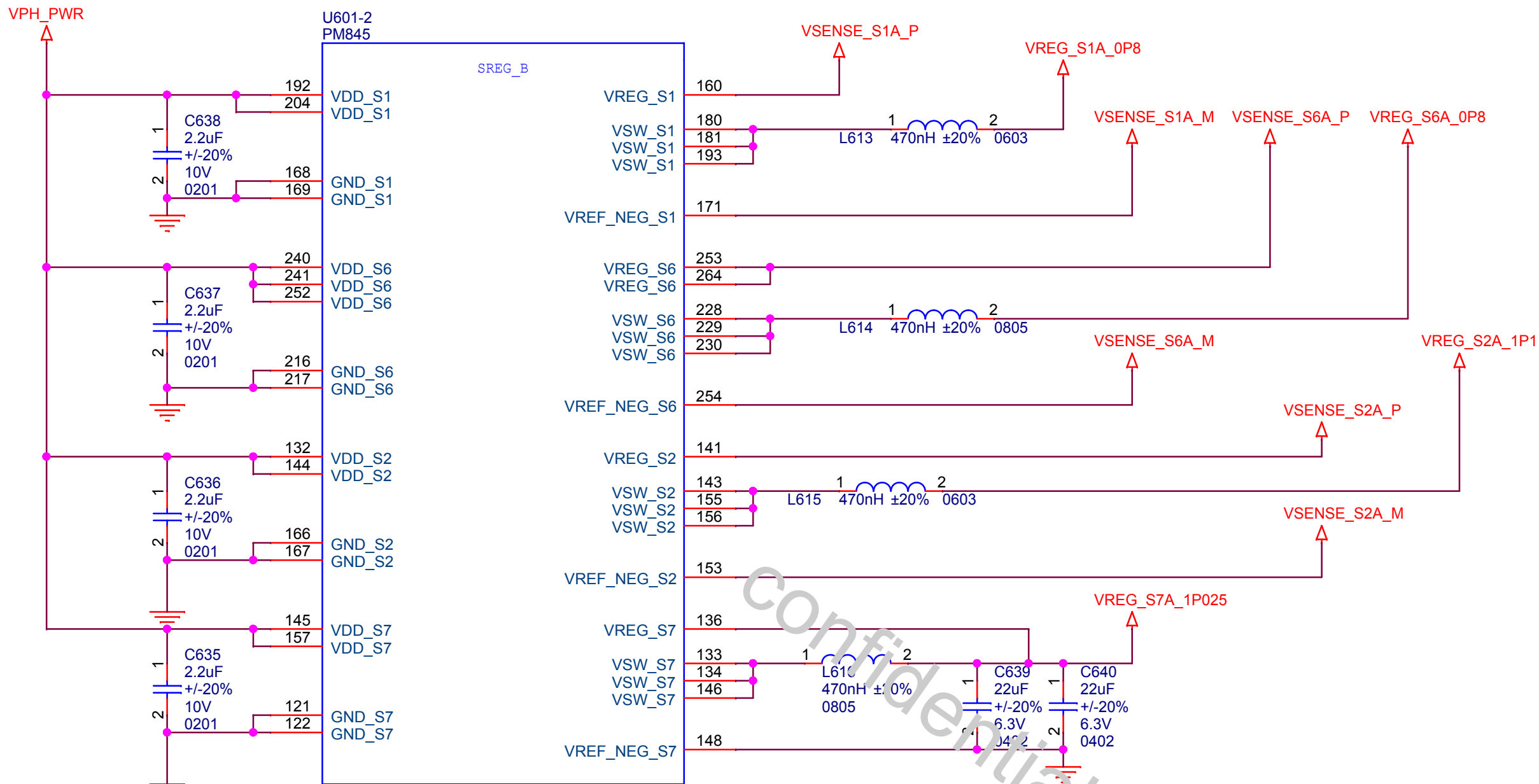

|       |                        |                 |                |   |       |
|-------|------------------------|-----------------|----------------|---|-------|
| Title |                        | E8              |                |  |       |
| Size  | A4                     | Document Number | PM845 SREG B&C |   | Rev   |
| Date: | Friday, March 23, 2018 |                 | Sheet          | 30  | of 44 |



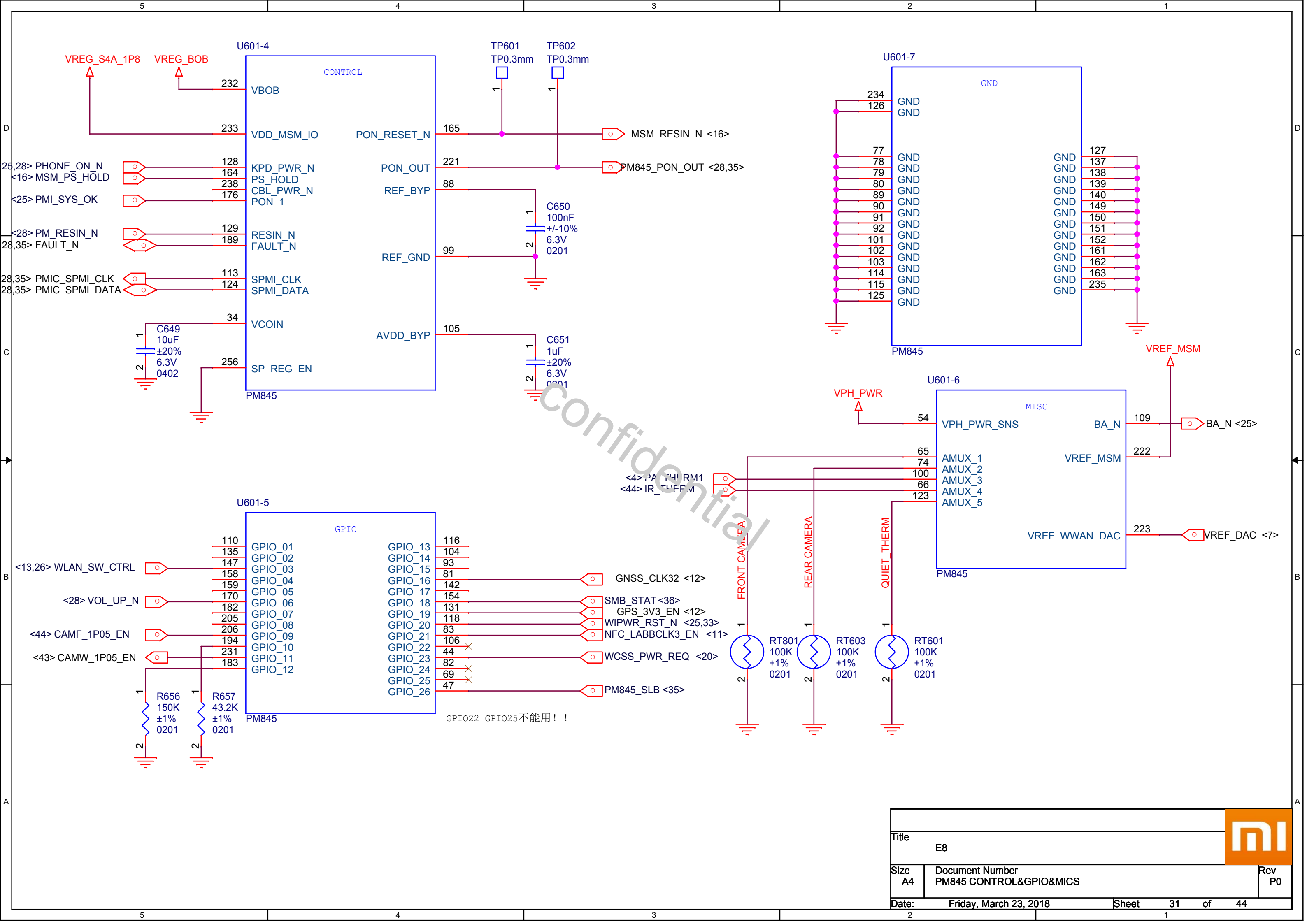

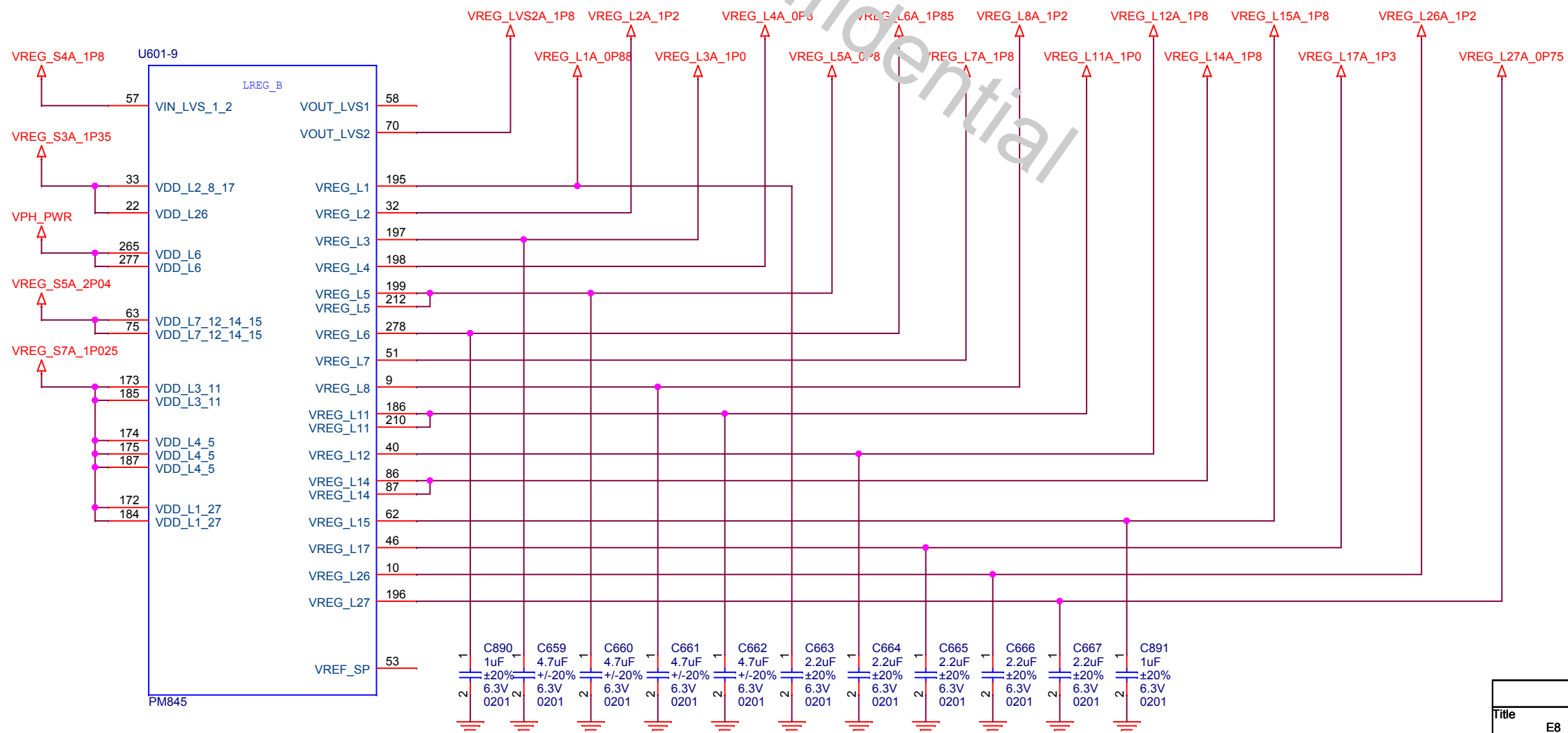
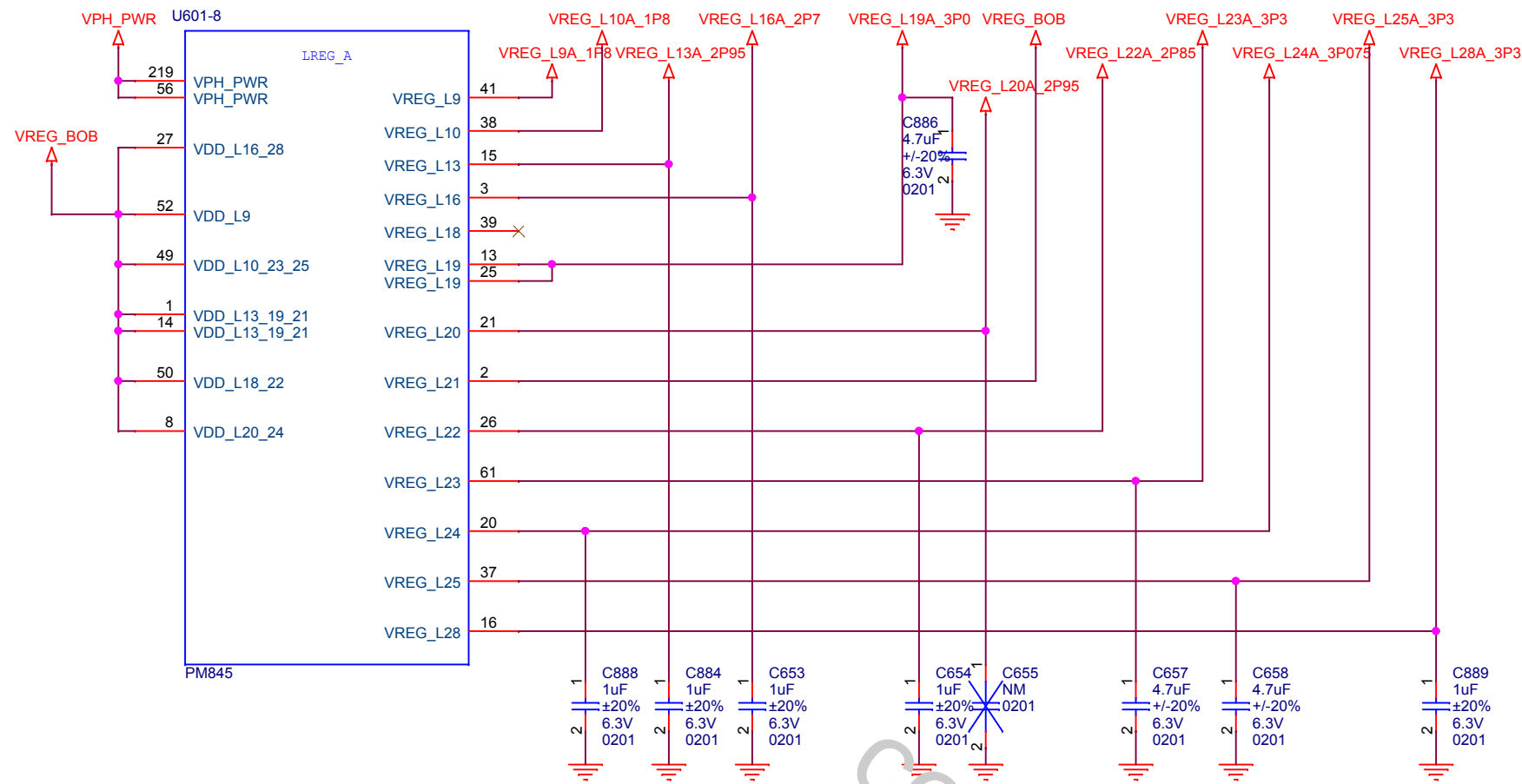

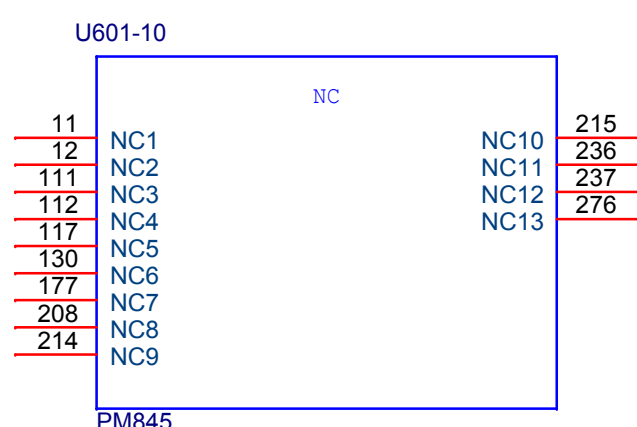
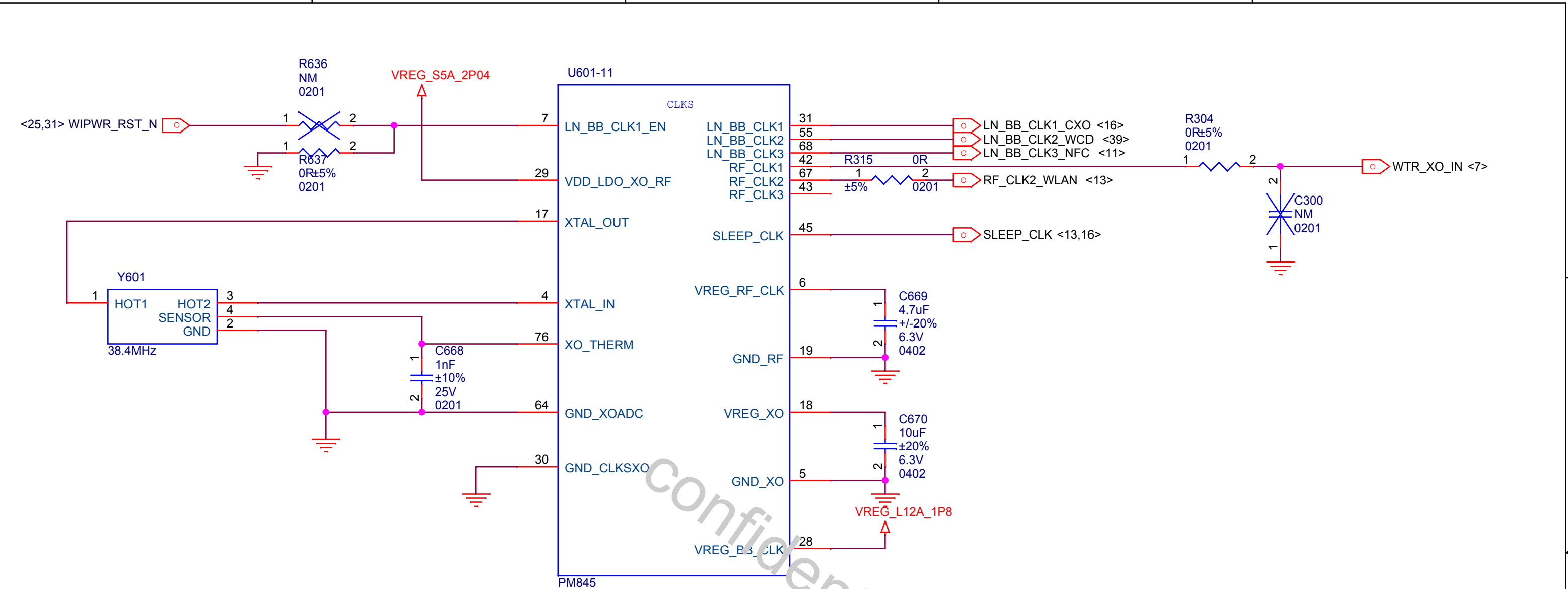

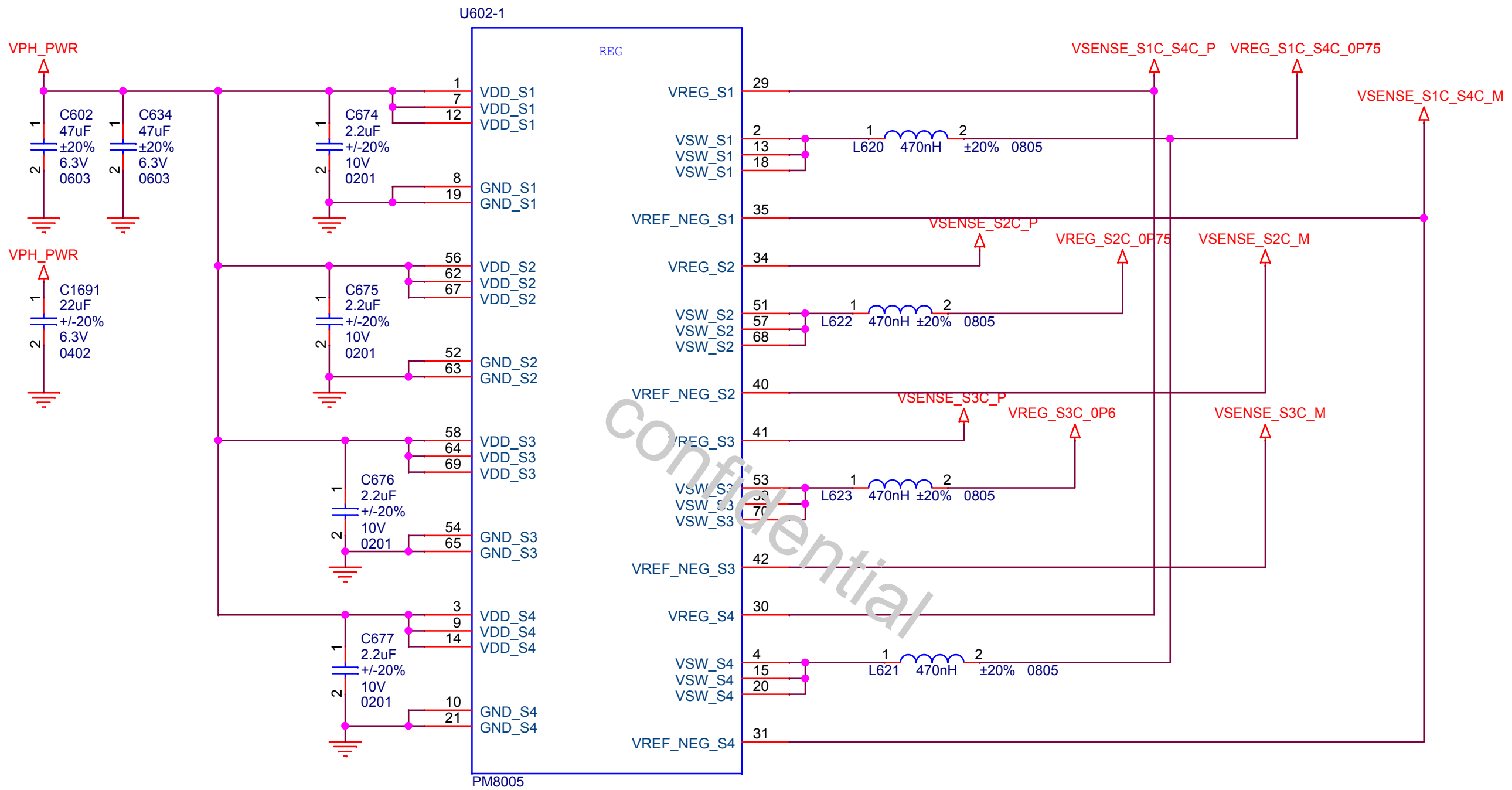

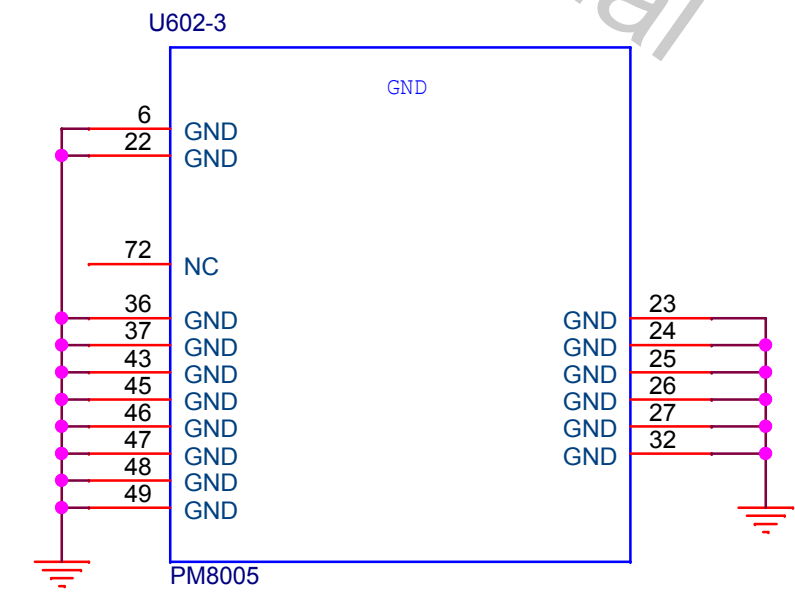
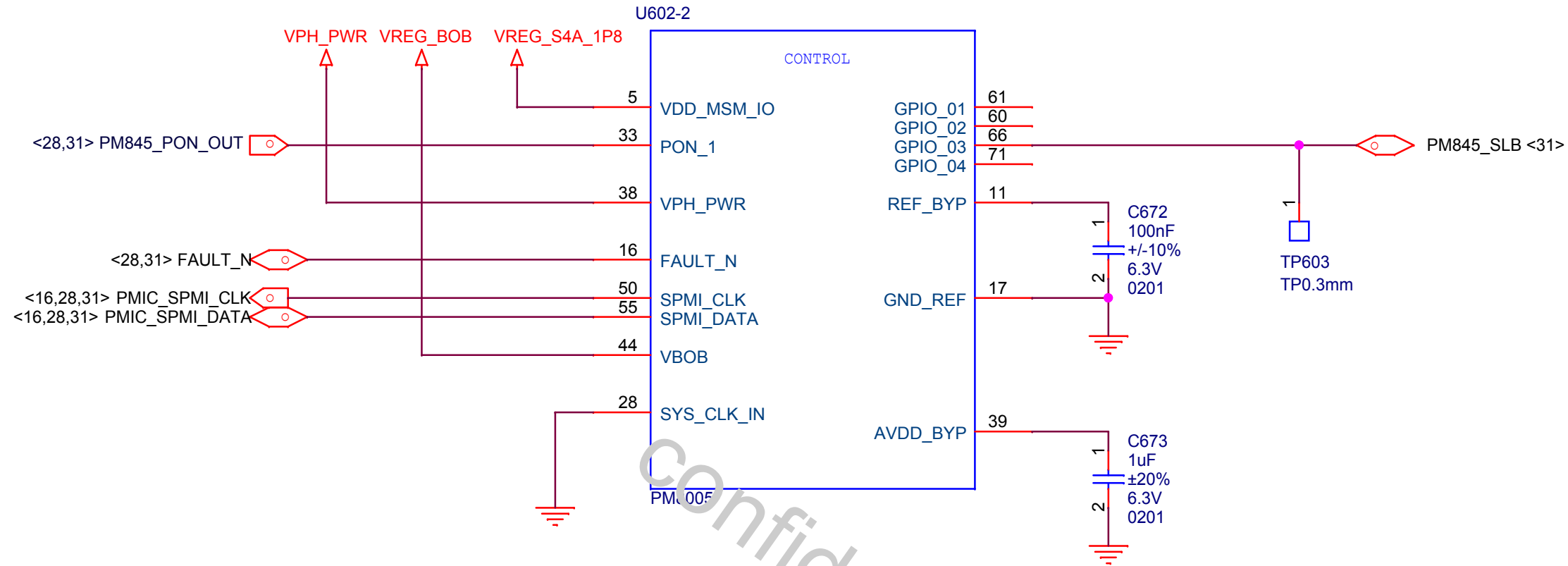



Confidential

|       |                        |                 |                    |   |     |
|-------|------------------------|-----------------|--------------------|---|-----|
| Title |                        | E8              |                    |  |     |
| Size  | A4                     | Document Number | PM8005 CONTROL&GND |   | Rev |
| Date: | Friday, March 23, 2018 | Sheet           | 35                 | of  | 44  |

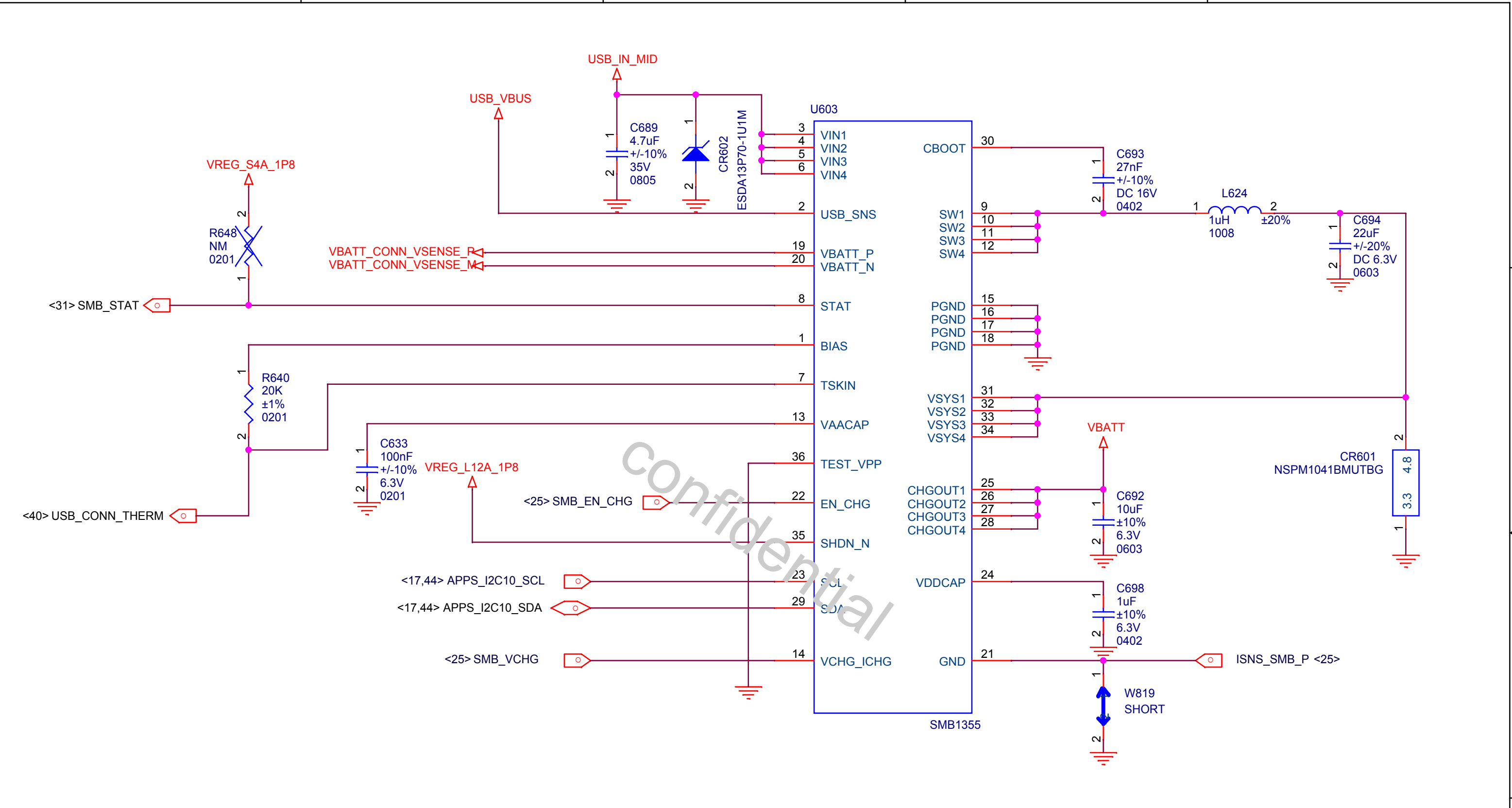

Confidential

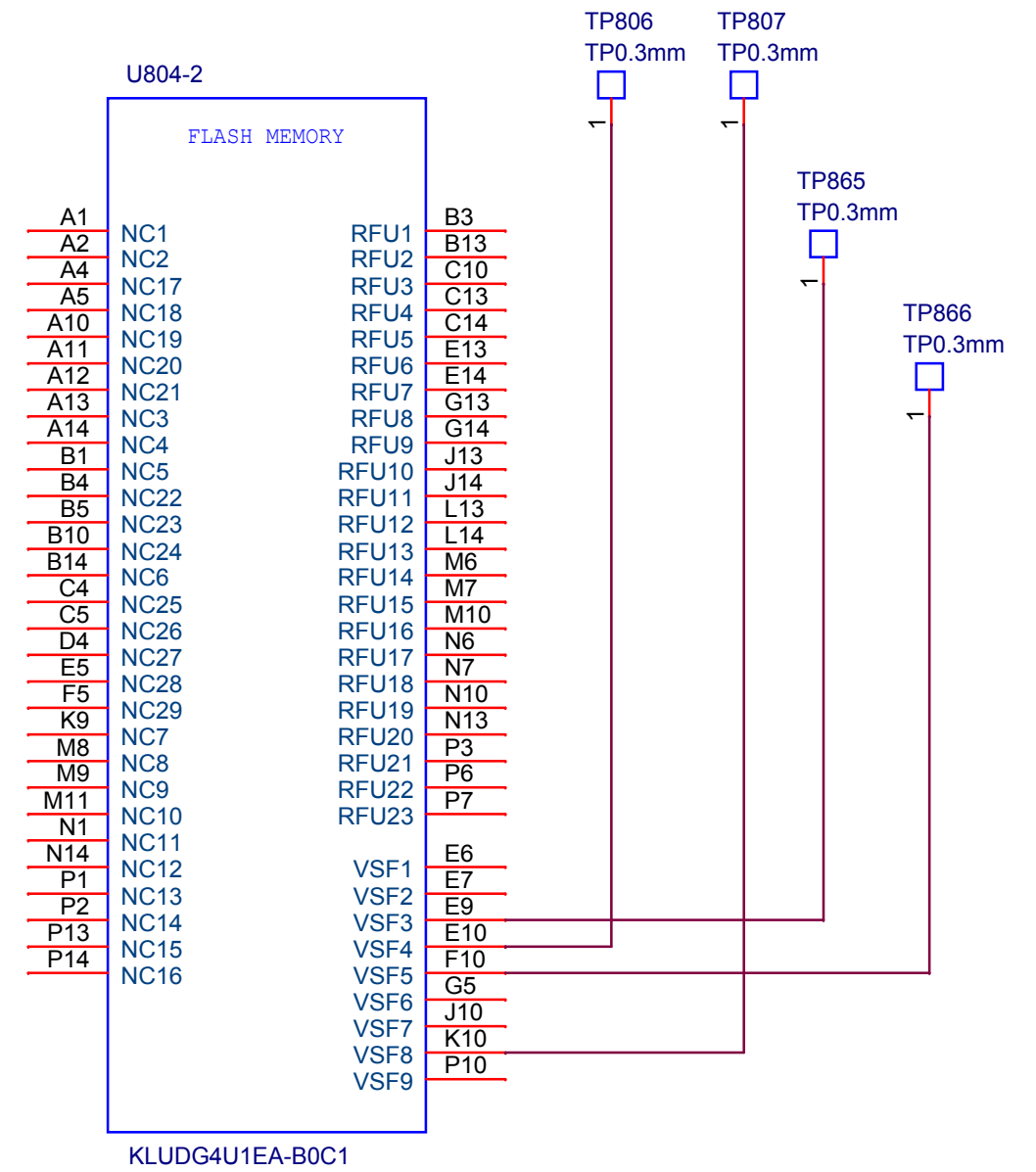
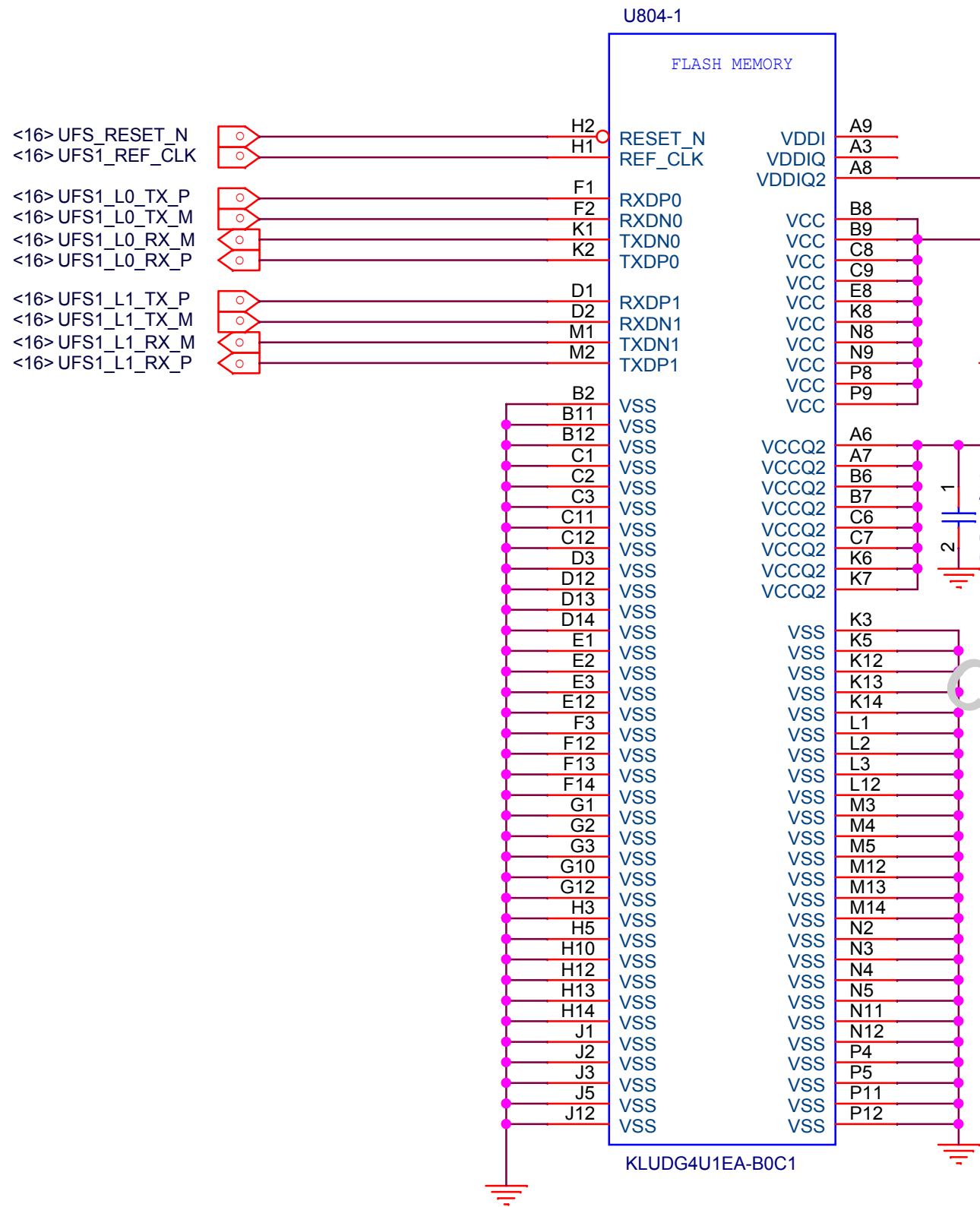

# Speaker PA

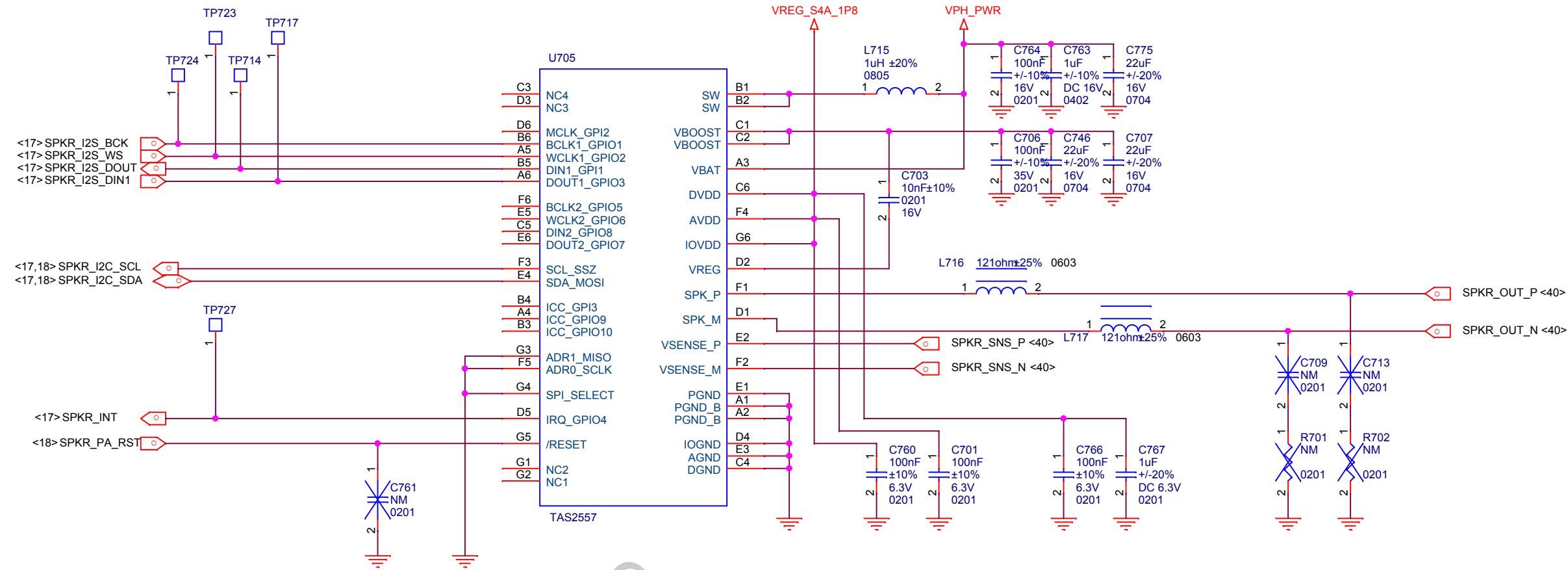

# AUX Mic

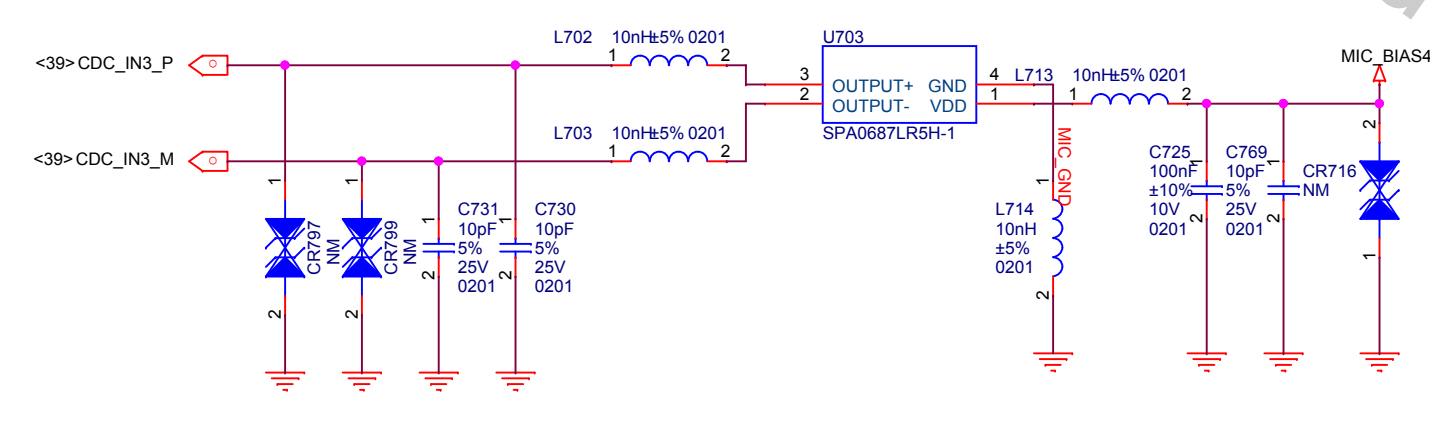

# Receiver

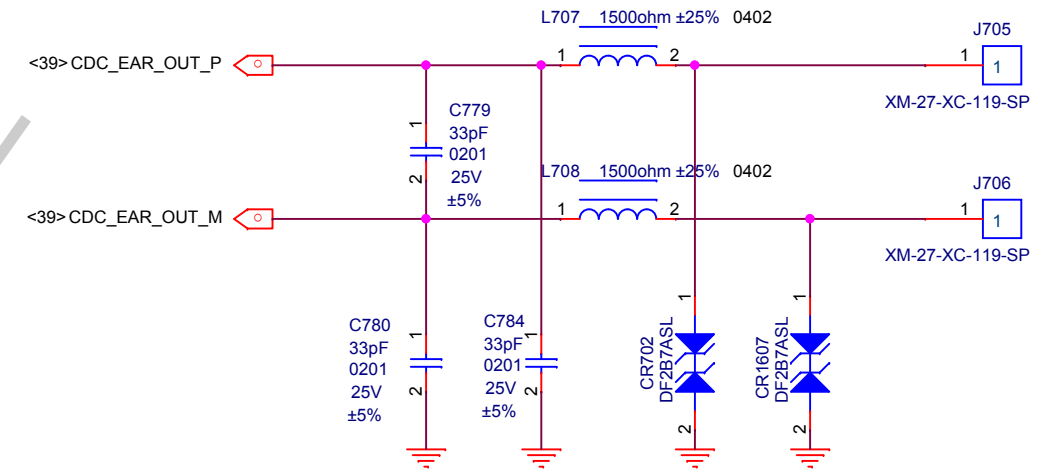

# HEADSET

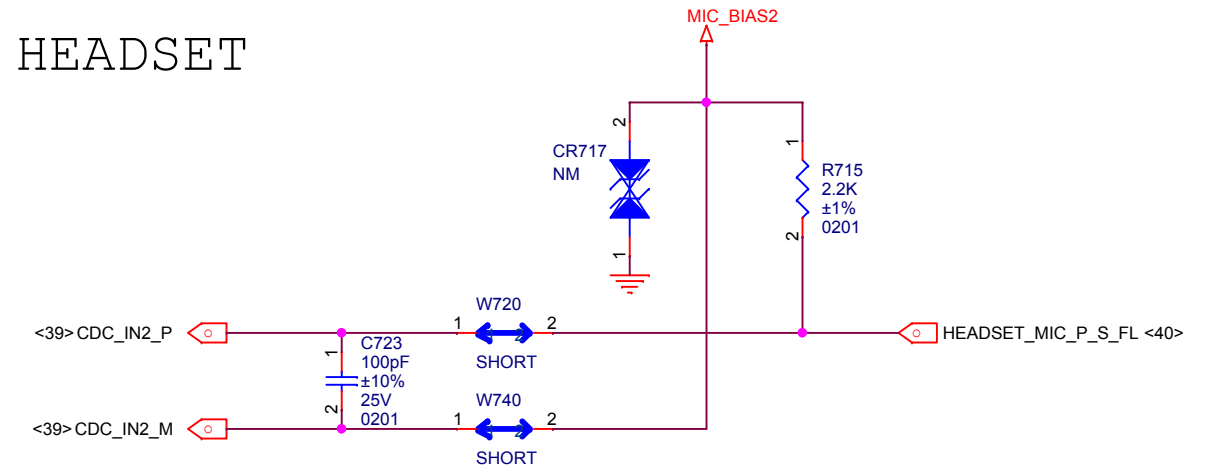

Confidential

|       |                        |       |          |
|-------|------------------------|-------|----------|
| Title |                        | E8    |          |
| Size  | Document Number        | A3    |          |
| Date: | Friday, March 23, 2018 | Sheet | 38 of 44 |



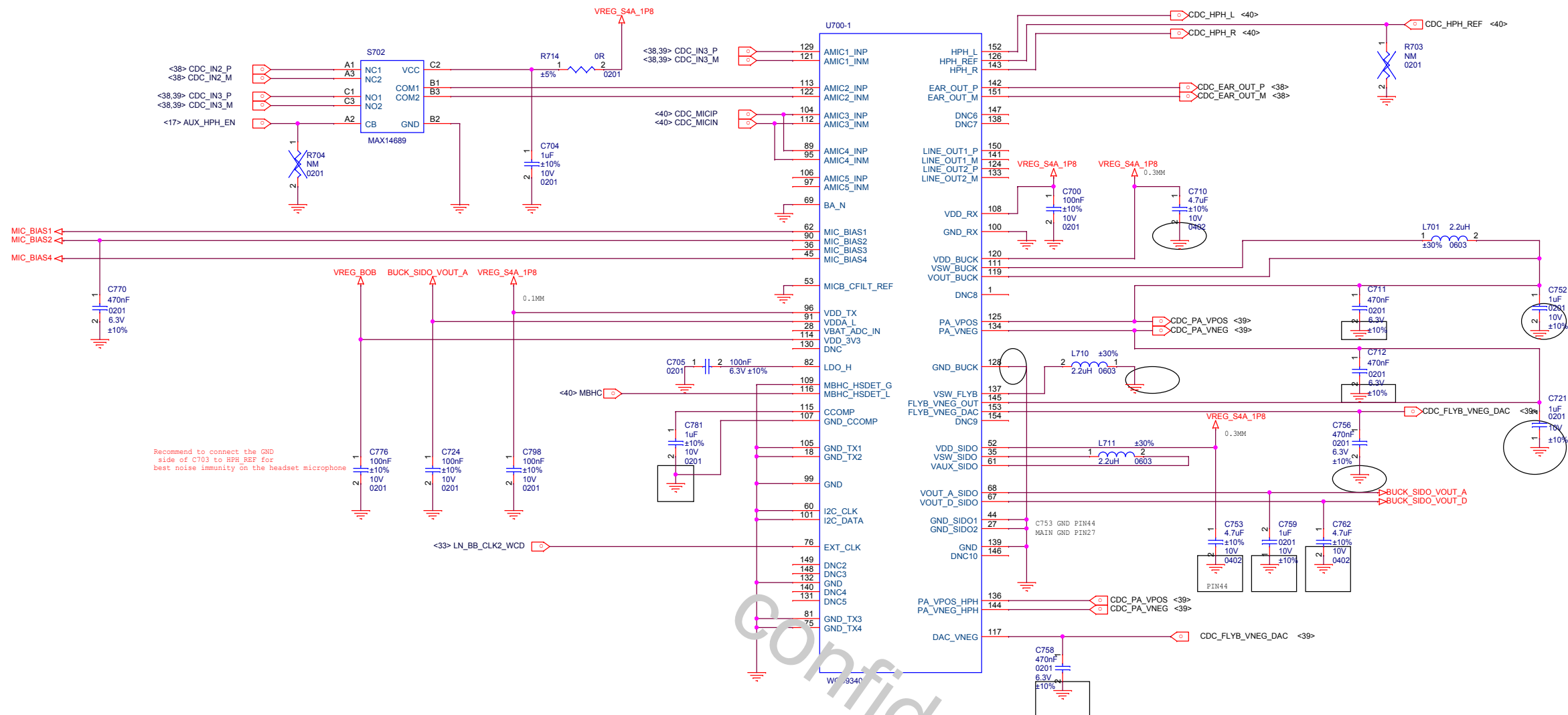

Recommend to connect the GND side of C703 to HBZ BZF for best noise immunity on the headset microphone

Confidential

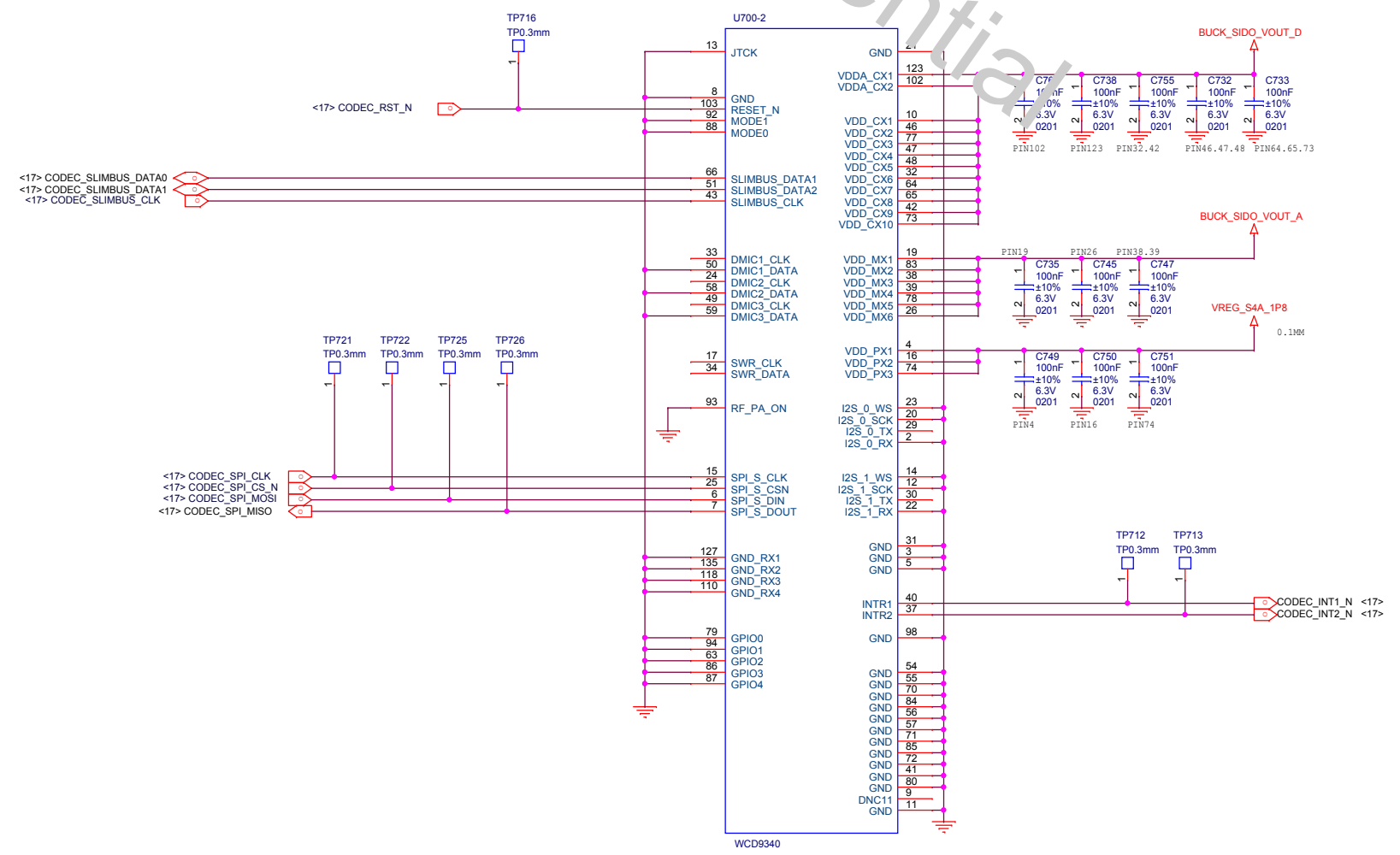

# LCD PWR

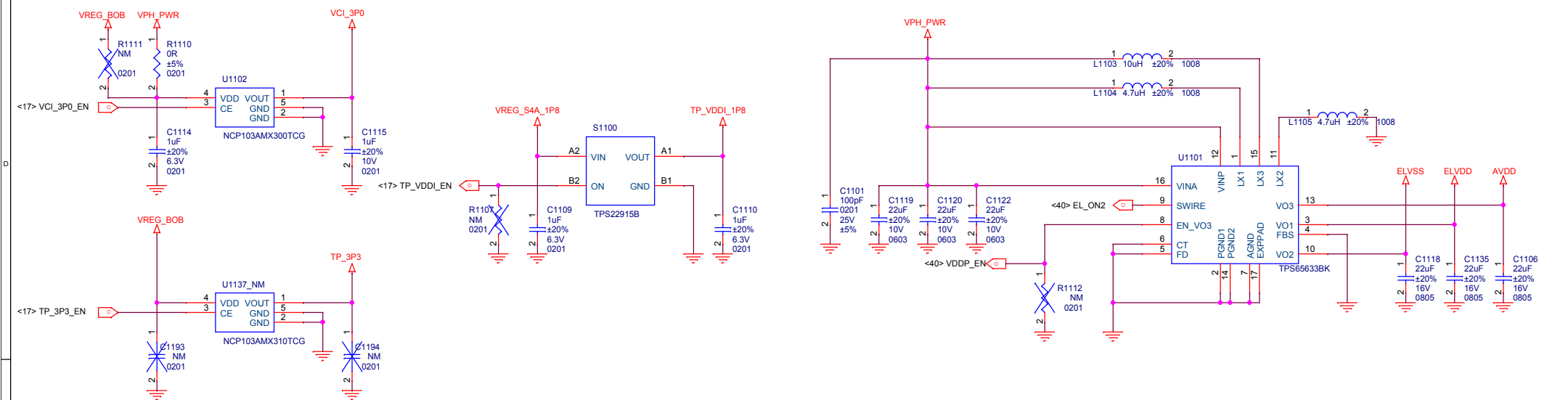

# LCD Filter

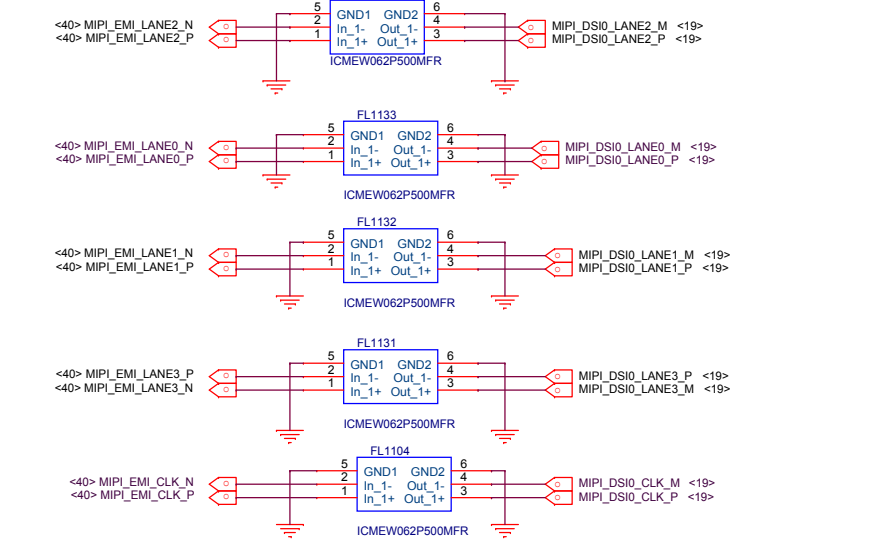

# LCD Connector PIN MAP!!!

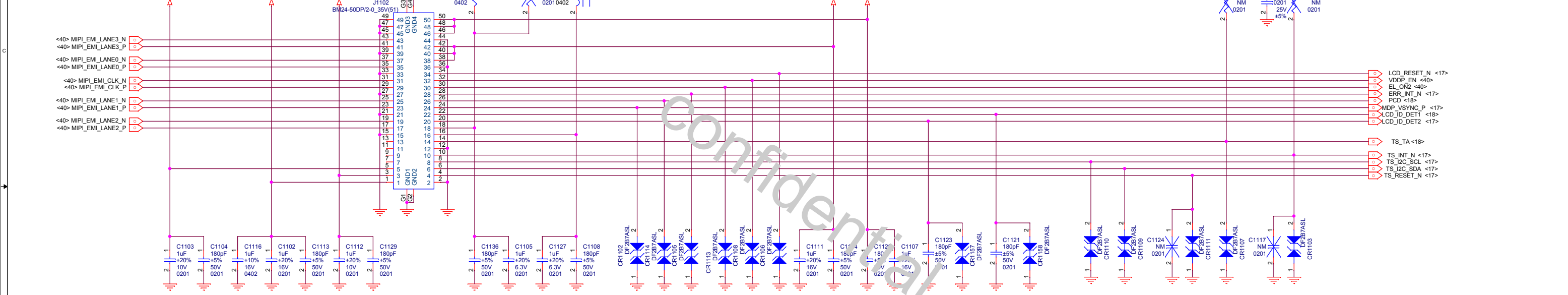

# BTB Connector

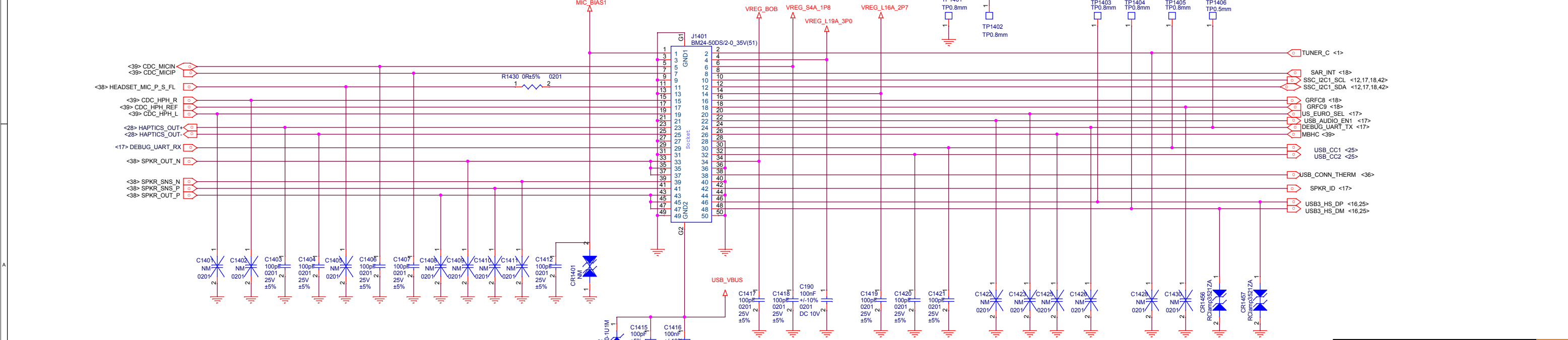

|       |                        |                |
|-------|------------------------|----------------|
| Title | E8                     |                |
| Size  | Document Number        | Rev            |
| A2    | LCD&BTB                | P0             |
| Date: | Friday, March 23, 2018 | Sheet 40 of 44 |

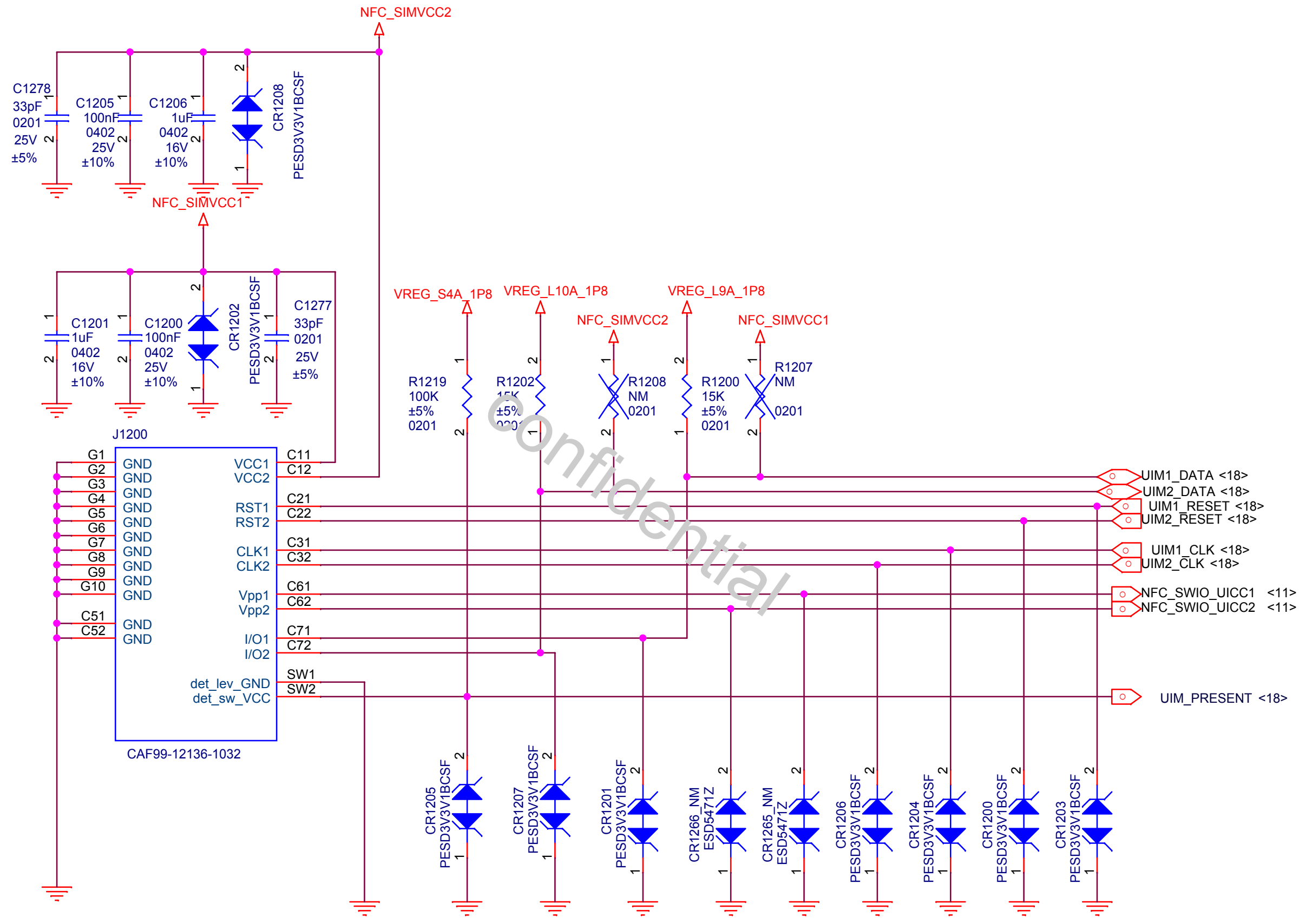

|       |                 |   |
|-------|-----------------|---|
| Title |                 |  |
| E8    |                 |   |
| Size  | Document Number | Rev   |
| A4    | SIM CONNECTOR   | P0  |
| Date: | Sheet           | 41 of 44  |

# FINGERPRINT

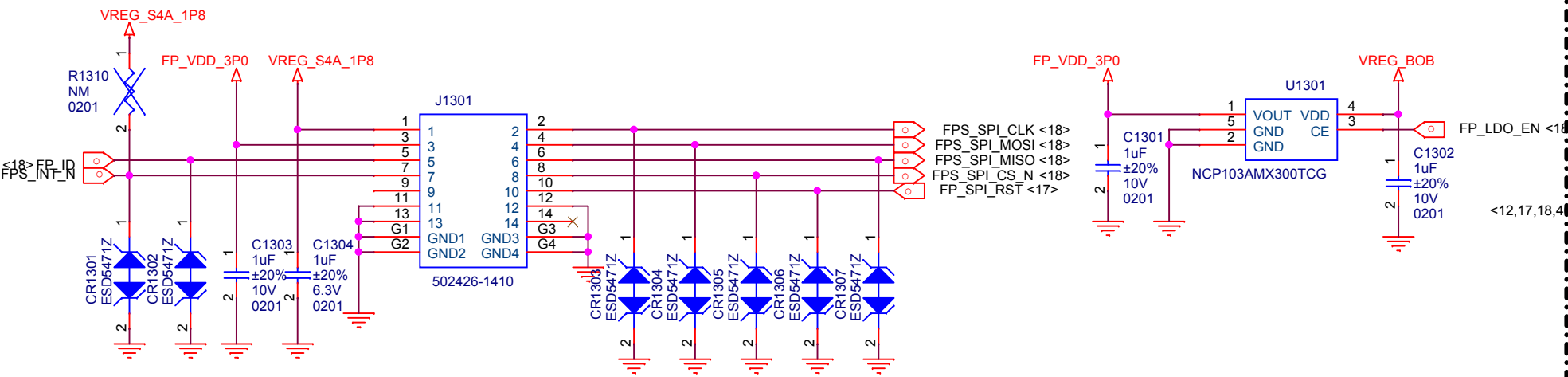

# PRESSURE

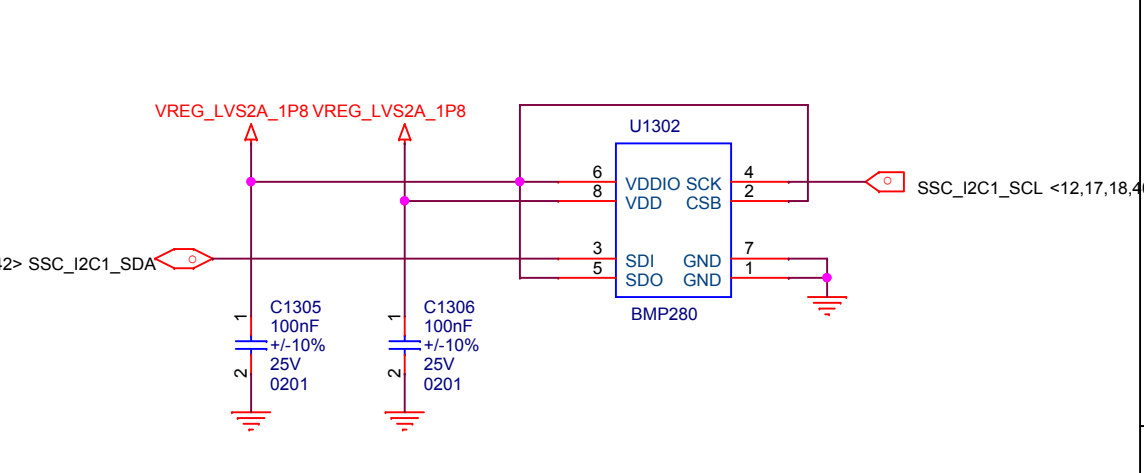

# GYRO

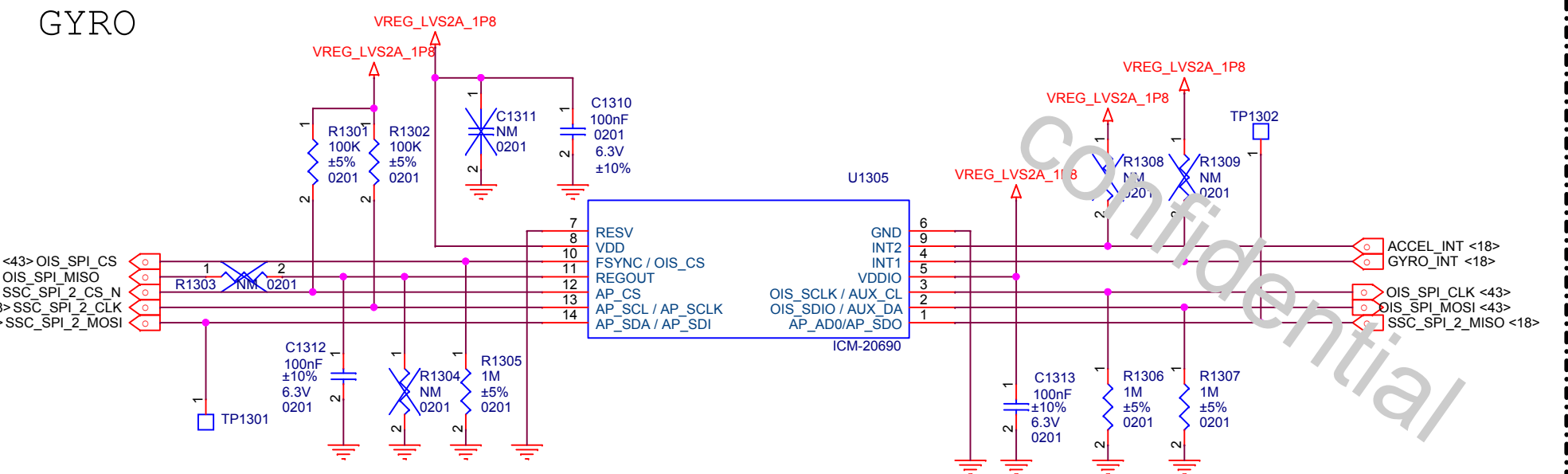

# COMPASS

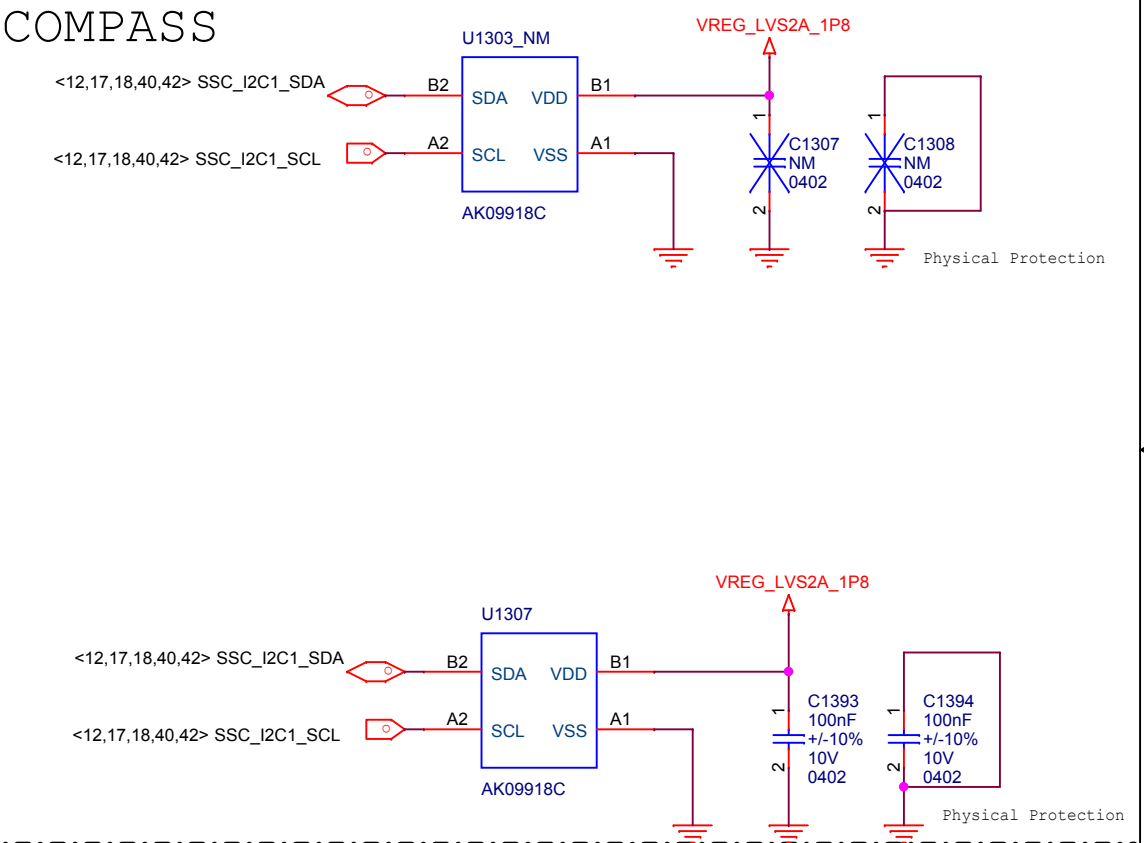

# P-SENSOR

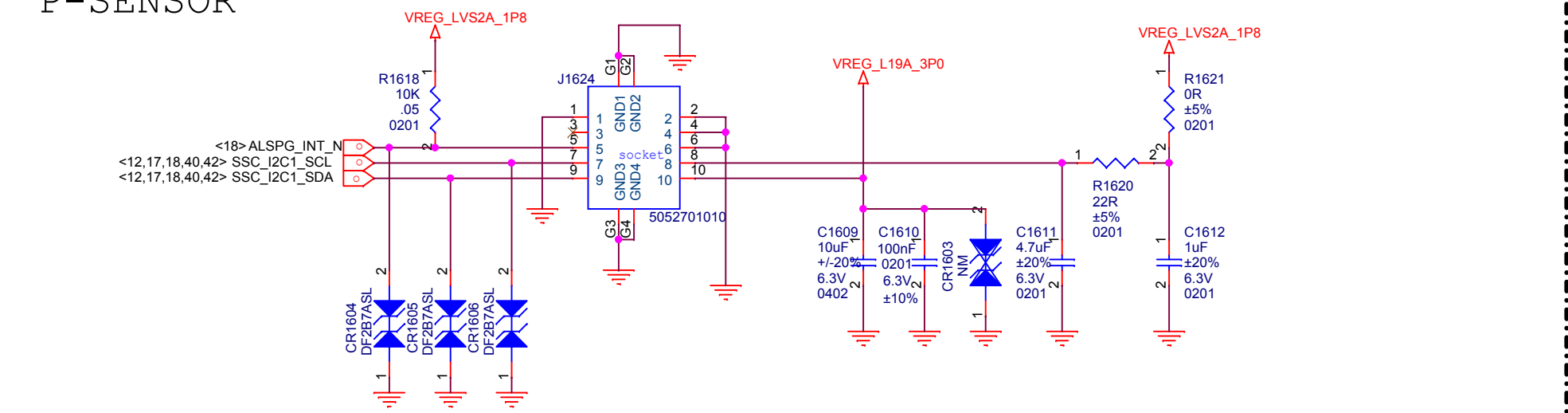

# HALL

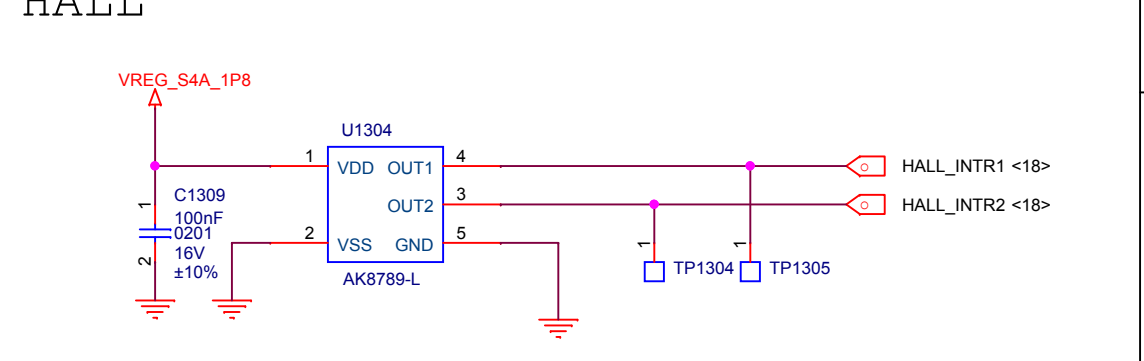

# LDOs

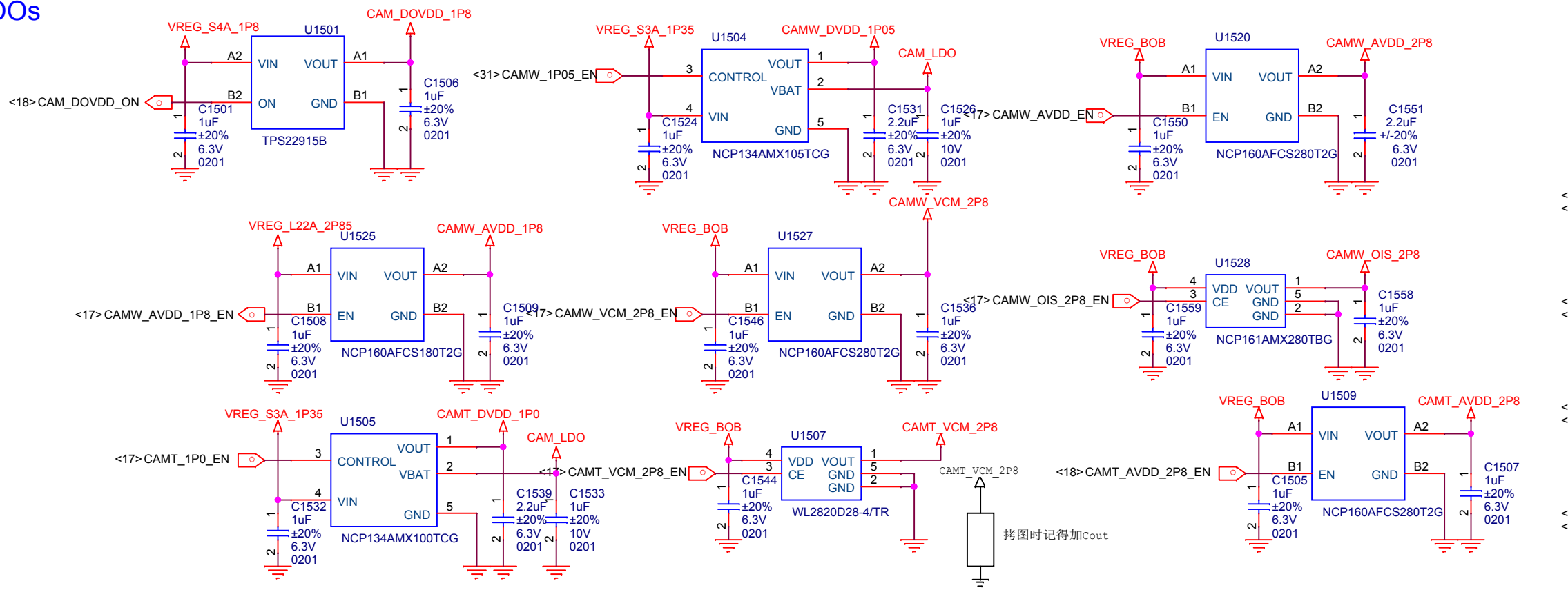

# REAR EMI

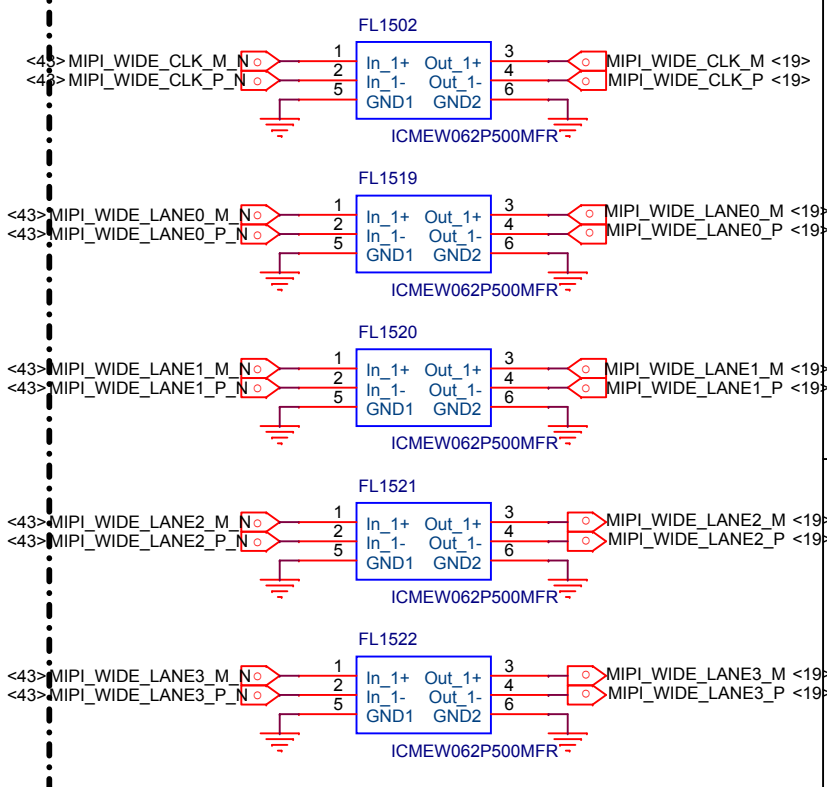

# REAR CAMERA

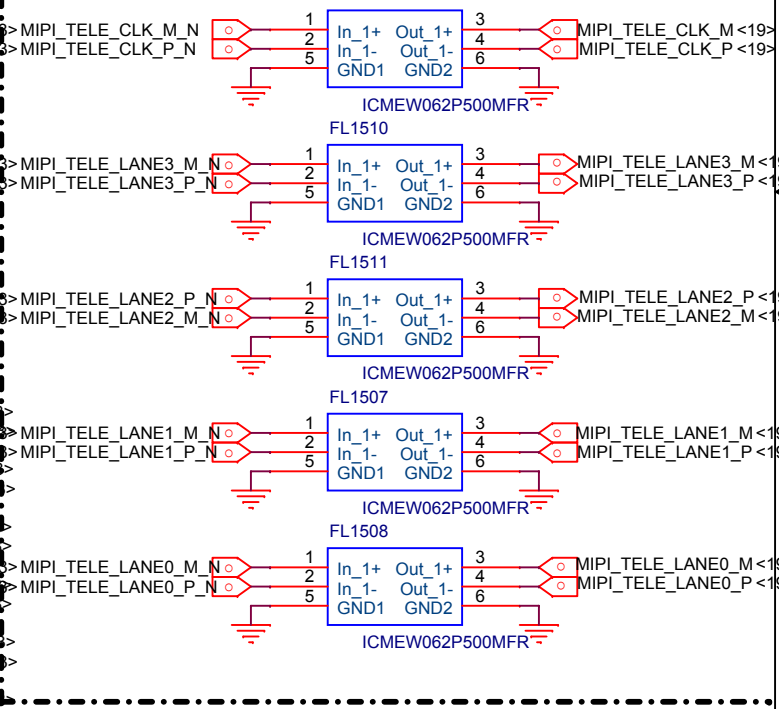
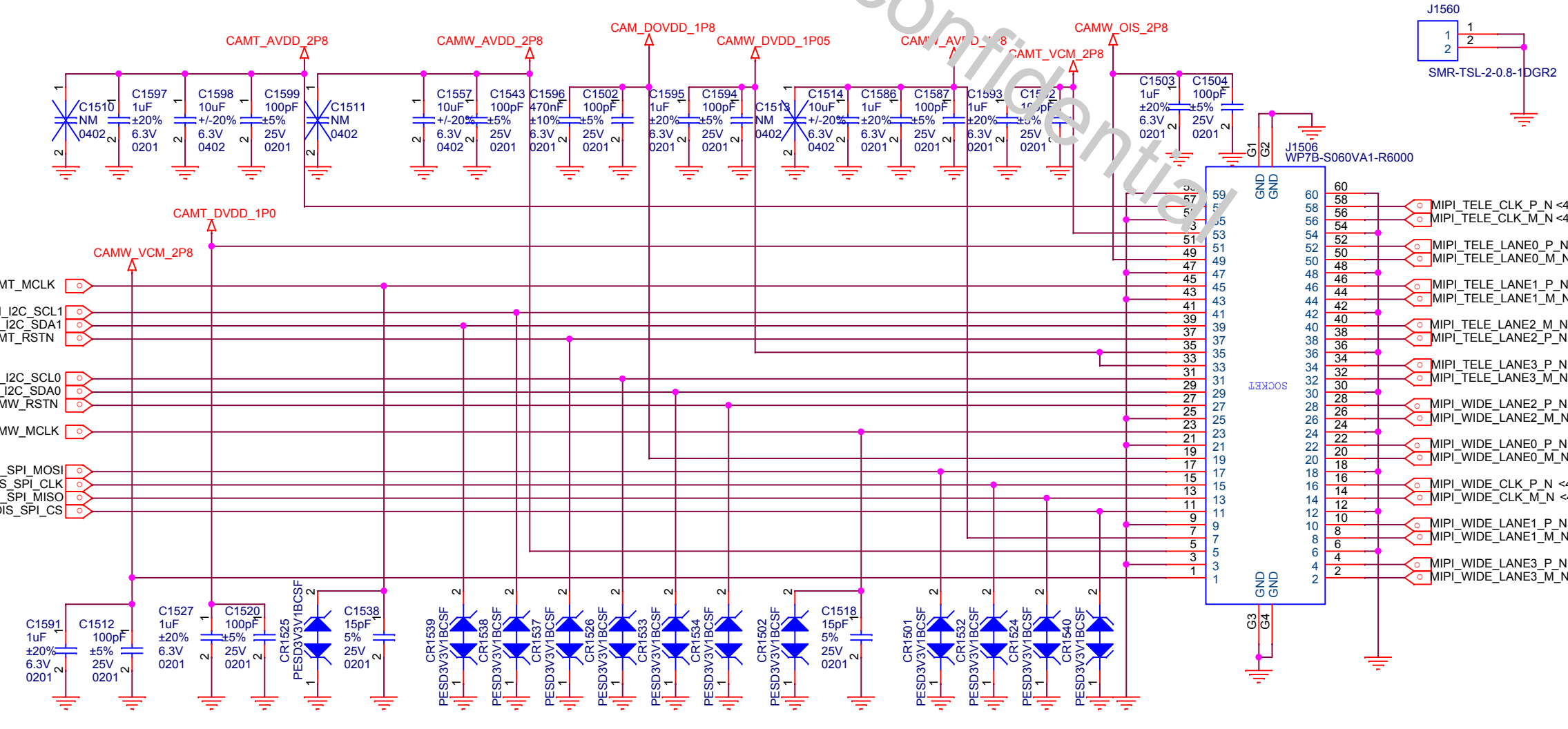

# FLASH

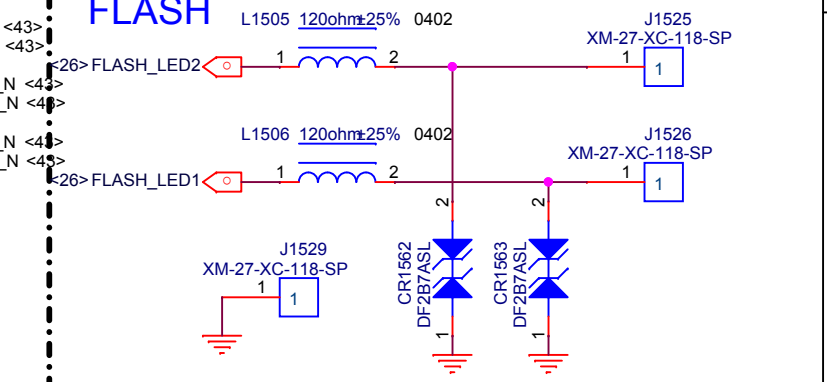

|       |    |                 |                   |
|-------|----|-----------------|-------------------|
| Title |    | E8              |                   |
| Size  | A3 | Document Number | REAR CAMERA&FLASH |
| Date: |    | Rev             | P0                |
|       |    | Sheet           | 43 of 44          |



# LDOs

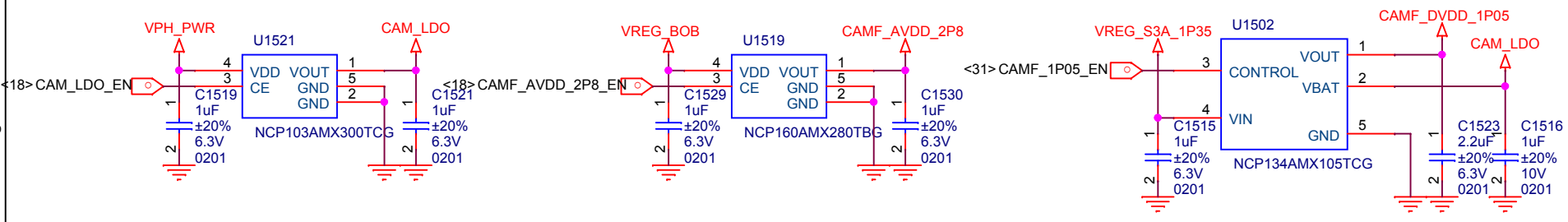

# IR CAMERA

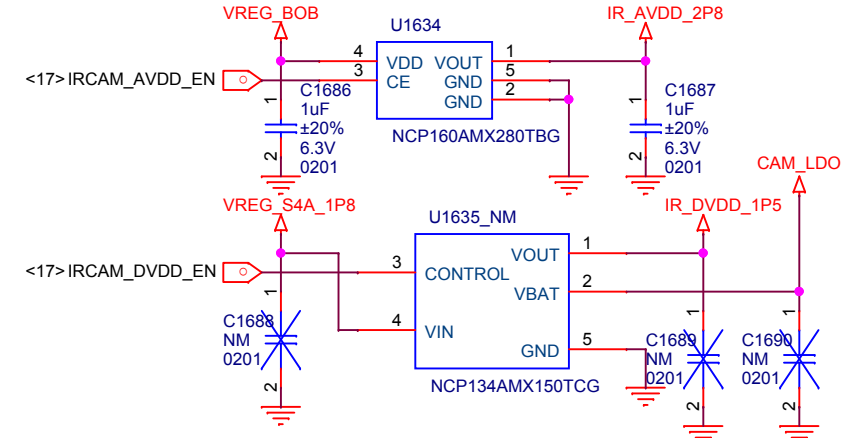

# FRONT CAMERA

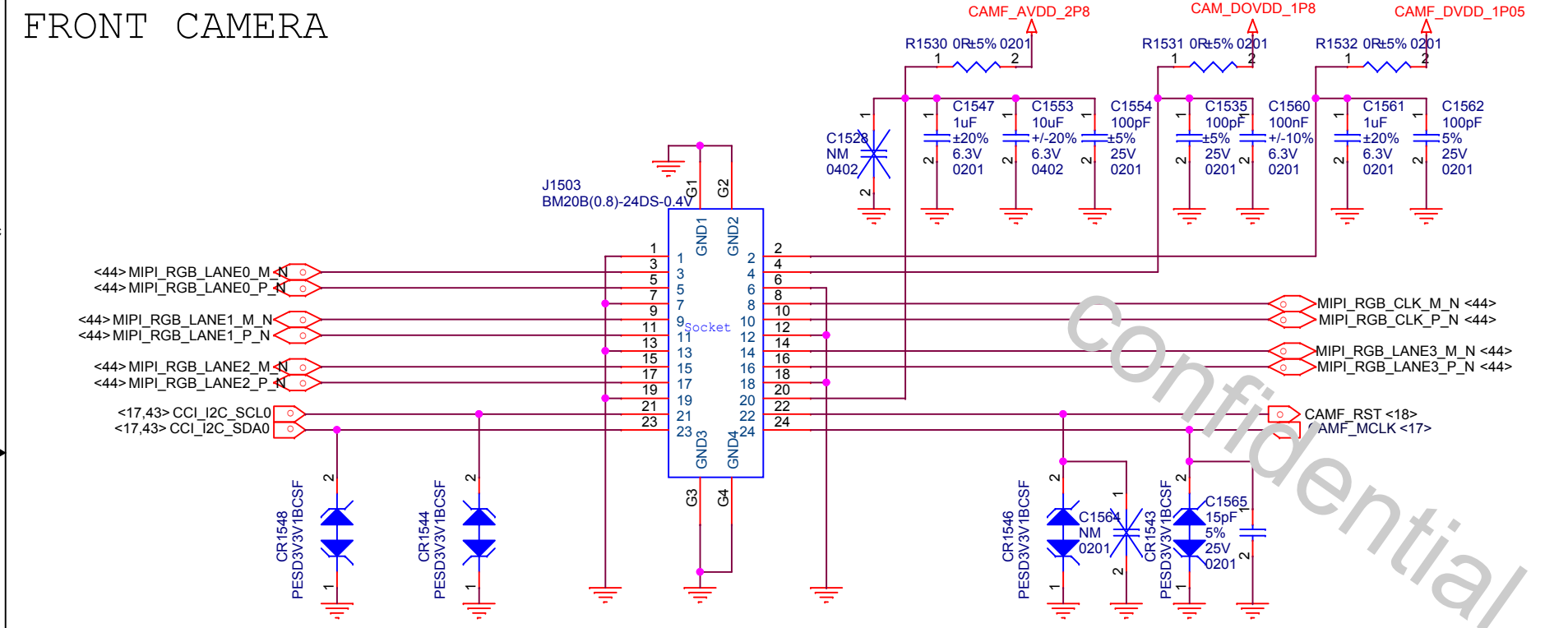

# FRONT EMI

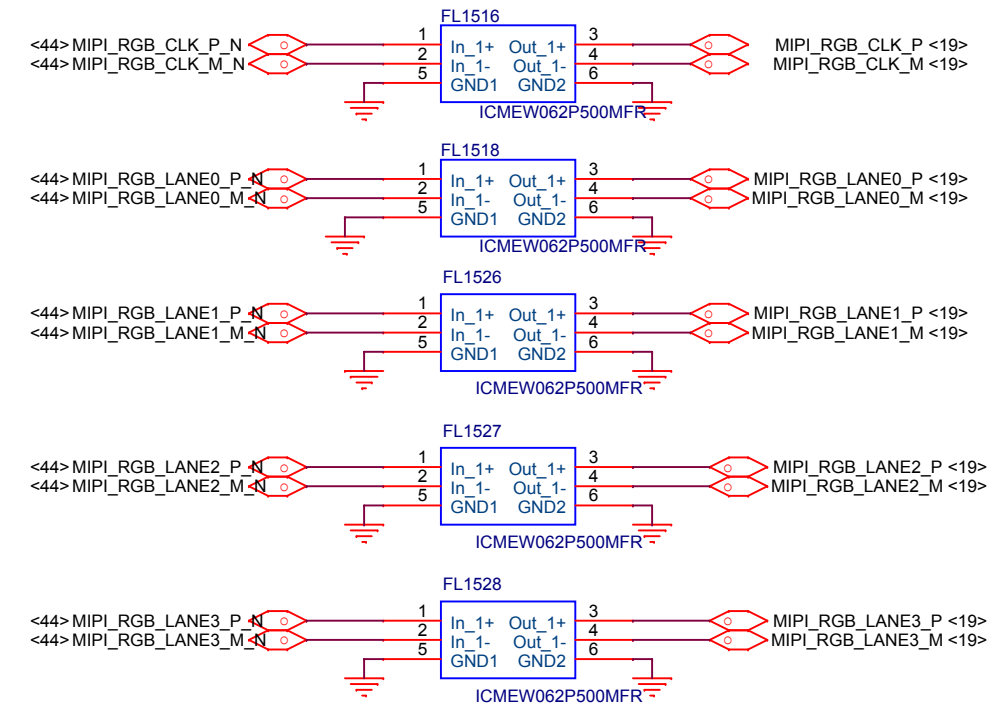

# IR CAMERA

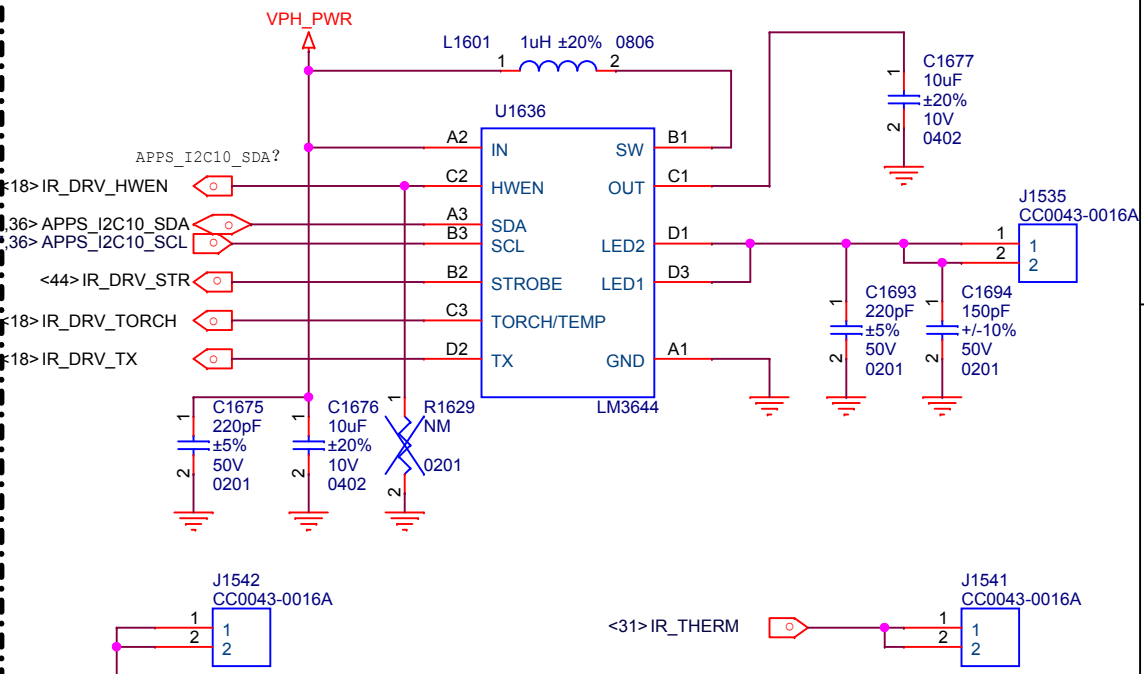
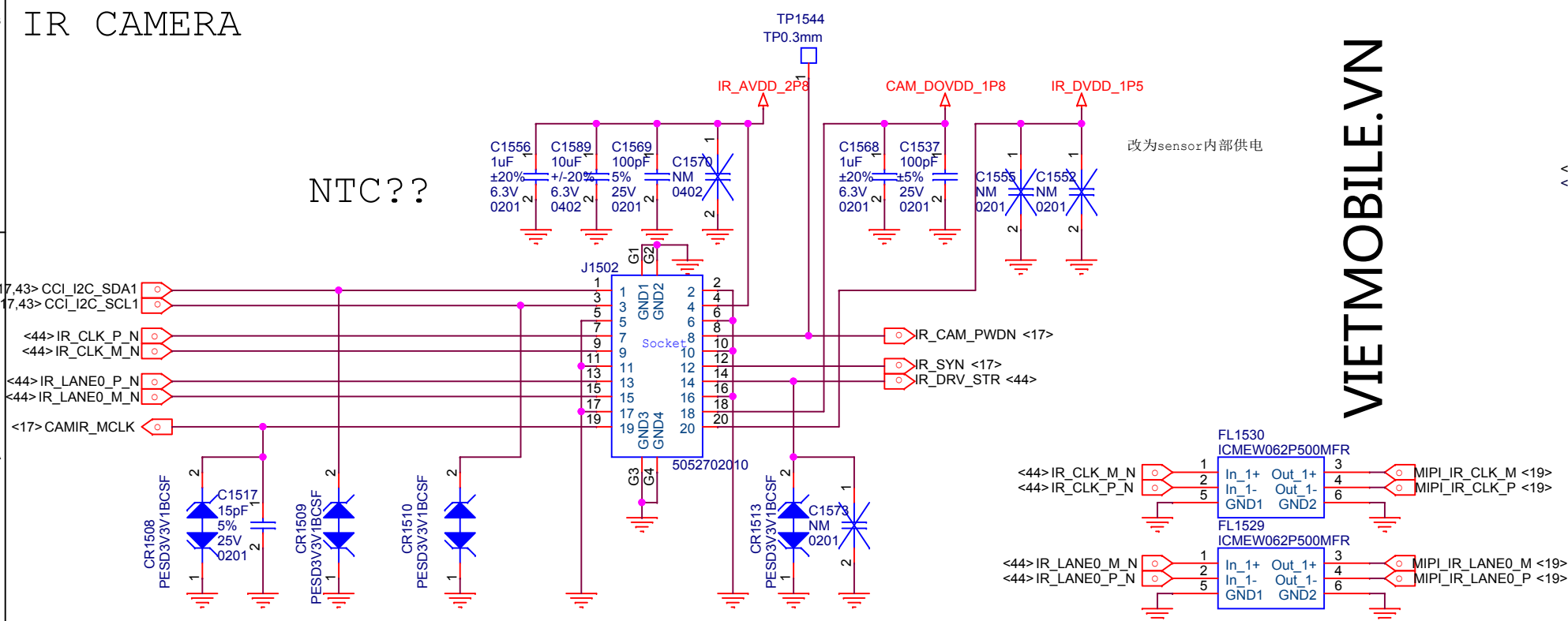

VIETMOBILE.VN

|       |    |                 |          |
|-------|----|-----------------|----------|
| Title |    | E8              |          |
| Size  | A3 | Document Number |          |
| Date: |    | Sheet           | 44 of 44 |

